



SPACE STEP

Taking storage to new levels

www.blum.com

 **blum**[®]

Nice and practical

You need the right furniture concepts for customers who want to store lots of things. SPACE STEP not only allows you to use higher cabinets, but also creates extra storage space in the kickboard of base cabinets. Two solutions rolled into one.

blum

New storage

SPACE STEP gives you a step platform and pull-out under the step (provided the plinth is at least 150 mm high). Of course, the higher the plinth (max. 250 mm), the bigger the storage space. Ideal for items that are not used often.

Versatility in application

There are three different plinth options to choose from, making SPACE STEP suitable for many applications throughout the home.

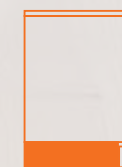

Recessed plinth



Recessed low plinth

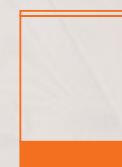

Flush plinth

Nice and high

The trend towards smaller living areas presents kitchen designers with new challenges. The new SPACE STEP plinth solution allows you to use the space right up to the ceiling and gives your customers easy access to the next higher storage level.

blum



Inspiring range

AVENTOS, our inspiring range of lift systems, provides easy access to items in wall cabinets. Users still have full freedom of movement even when cabinet fronts are open.



Systematic design

Upgrade the SPACE TOWER pantry unit with the two-fold benefits of SPACE STEP. First, create extra storage space under the step. Second, provide easy access to storage items on the top shelf.

Nice and gentle

Every kitchen designer would like to combine beautiful design with functionality and convenience. Thanks to motion technologies by Blum, SPACE STEP opens and closes softly and effortlessly.

blum

Functional convenience

SPACE STEP can be implemented with LEGRABOX, TANDEMBOX and MOVENTO box and runner systems. To give your customers enhanced convenience, combine the plinth solution with tried and tested motion technologies by Blum.

BLUMOTION
by Blum

**TIP-ON
BLUMOTION**
by Blum

Fascinatingly simple

The SERVO-DRIVE electrical motion support system delivers supreme ease of use. SPACE STEP opens at a single touch anywhere on the front. And closes again softly and effortlessly with BLUMOTION.

SERVO-DRIVE
by Blum

Nice and safe

Surprise your customers with new ideas and applications. SPACE STEP was designed with safety in mind. The plinth solution provides a sturdy platform that is firmly held in place by a special anti-slip system.

blum



Anti-slip system

Activated by a weight of just 8 kg, the anti-slip system securely locks the SPACE STEP in position when extended. The step surface can take a maximum load of 150 kg, provided the construction is suitable. Note: Anti slip step surface not included.

New bathroom designs

Introduce accents and personality with SPACE STEP. The design capabilities enable designs that are wide or narrow, high or low, colour coordinated or contrast.

Nice and convenient

Cabinet makers and designers like their furniture planners to think ahead for them. SPACE STEP provides your customers with enhanced convenience before they need it. Now that's attentive service.

blum

Universal in application

For kitchens, bathrooms, living rooms and other living areas – SPACE STEP improves quality of living throughout the home. The plinth solution also has diverse applications in the commercial sector.



Find out more about
SPACE STEP here:
www.blum.com/spacestep

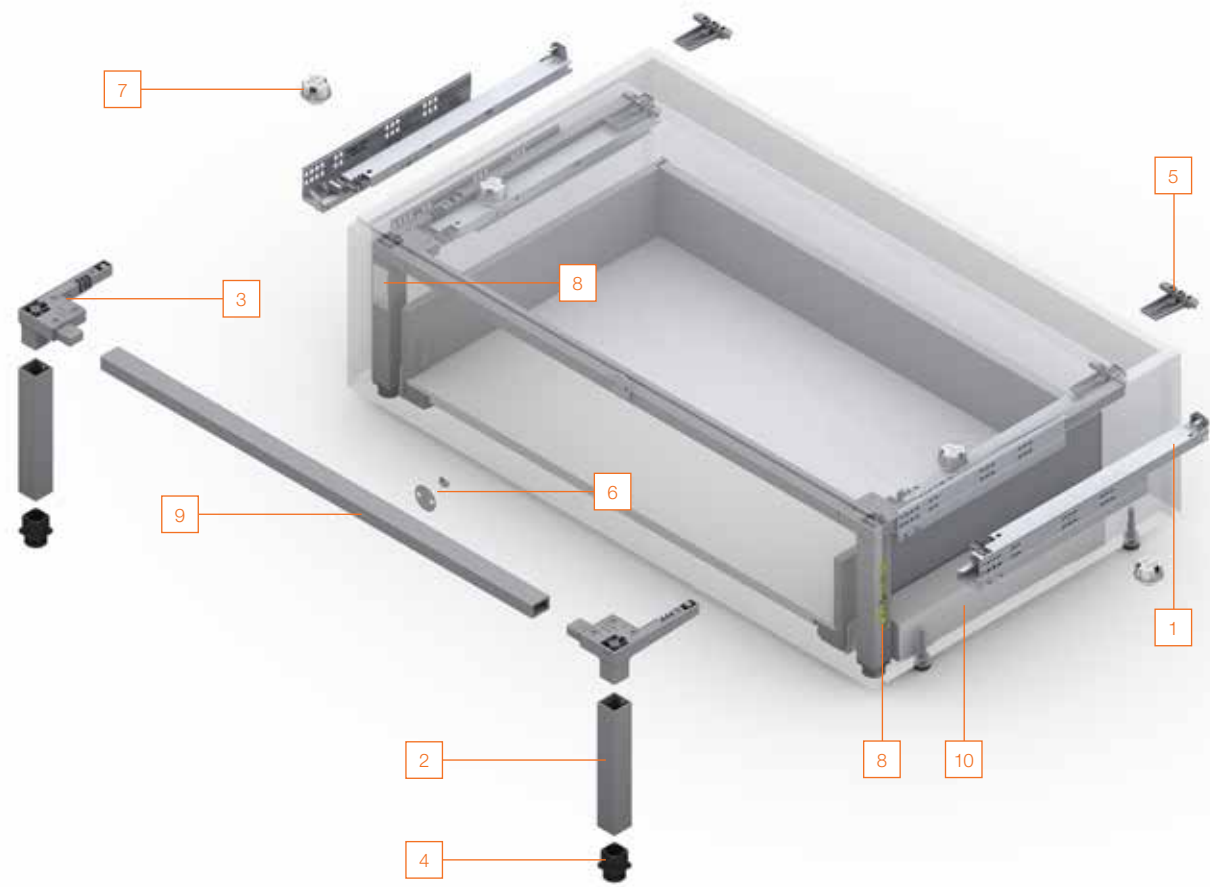

SPACE STEP set		
Nominal length (NL)	Colour	
410 mm	Orion grey matt	Z95.4100
460 mm	Orion grey matt	Z95.4600
Consisting of:		
1 2 x TANDEM 561Hxxx1B95 left/right		
2 2 x vertical support		
3 2 x corner connector		
4 2 x support foot		
5 2 x rear panel bracket		
6 1 x front connector set (magnet and catch plate)		
7 4 x spring bumper*		
8 2 x sticker (safety information and manufacturer information)		
14 x flat headed screw (4 x 15 mm)		
1 x installation instructions		
* Recommendation: Cabinet width (KB) > 900 mm, 4 pieces		

9 Horizontal cross profile	
	Aluminium
	For cutting to size Z95Q1040A
	Cutting dimensions: Internal cabinet width (LW) - 130 mm
	Recommendation: Cabinet width (KB) 1200 mm, use 2 pieces to prevent excessive bending

10 Spacer strip (optional)	
	For mounting the runners, suitable for all Blum box and runner systems
	* require two spacer strips per SPACE STEP
	Z95D4100

KB Cabinet width
LW Internal cabinet width

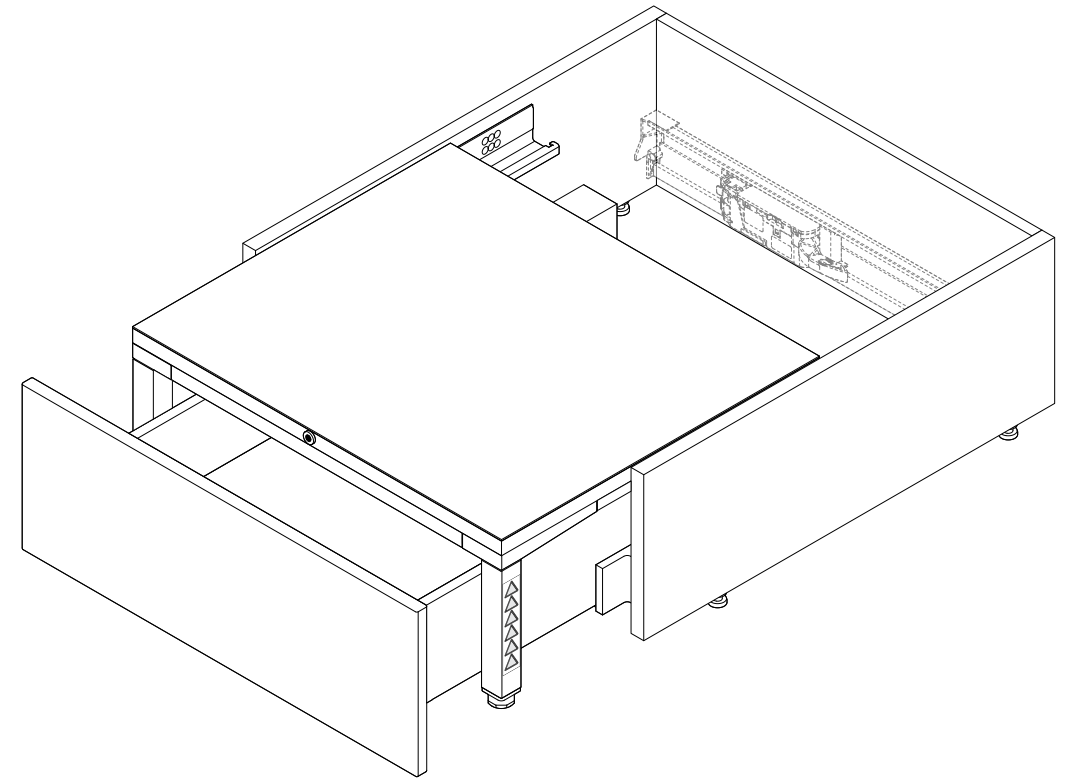

i Notes	
Maximum load: 150 kg*	
* As the manufacturer, you are responsible for determining the actual load bearing capacity of the furniture manufactured by you that uses the SPACE STEP as per EN-14183. This value must also be stated on the manufacturer label.	
Material recommendation: A 3-layer board (3S) at least 21 mm thick is recommended for the plinth step.	
Step surface recommendation: The step surface must be anti-slip. This can take the form of an anti-slip mat directly affixed to the step surface or by using anti-slip panel material. Note: Step surface material is not included	
Attaching the labels: EN-14183 requires both of the labels enclosed to be clearly displayed.	
Pull-out underneath SPACE STEP: Only 30 kg or 40 kg runners may be used. The dynamic carrying capacity for the pull-out underneath the SPACE STEP is 20 kg.	



LEGRABOX – height N

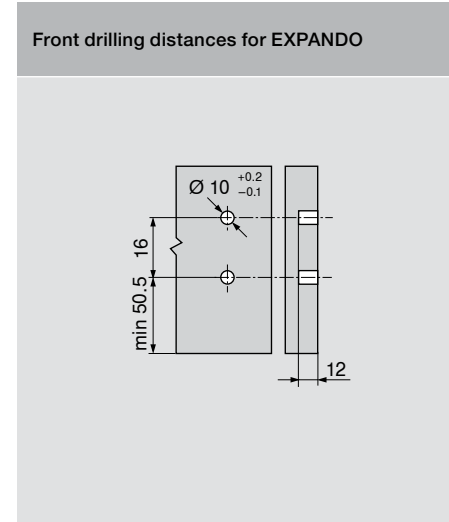
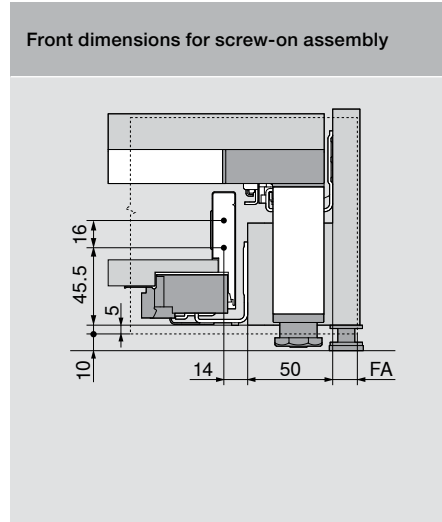
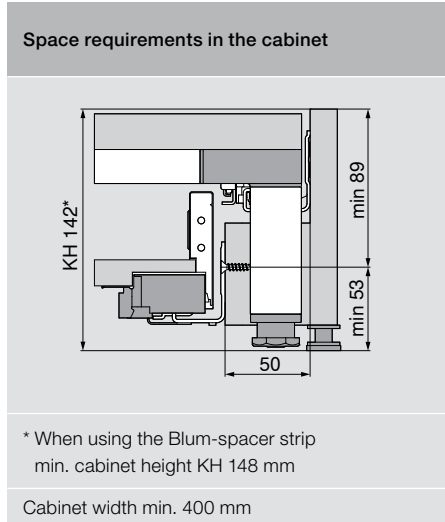

TANDEMBOX – height N

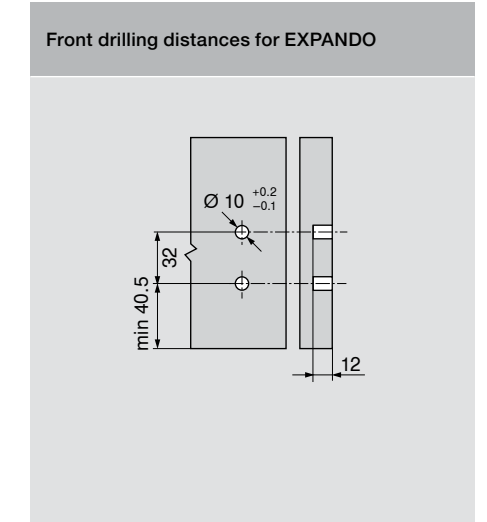
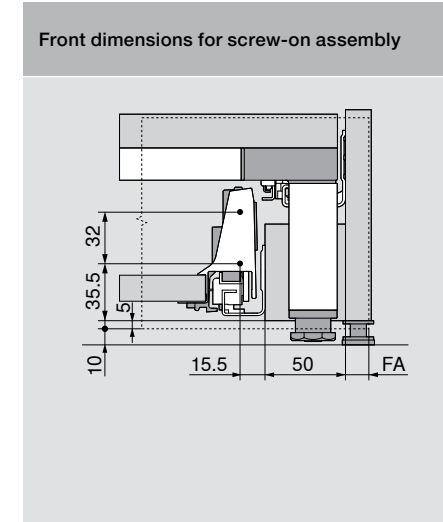
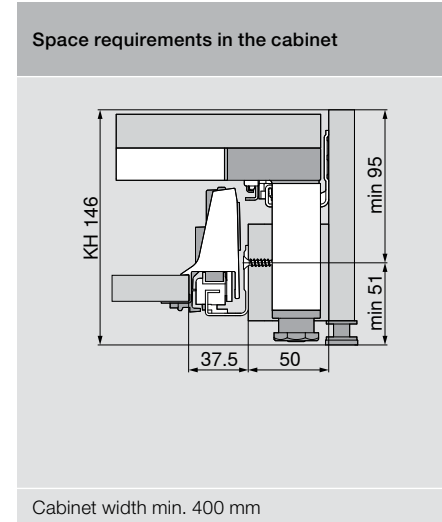

LEGRABOX – height M

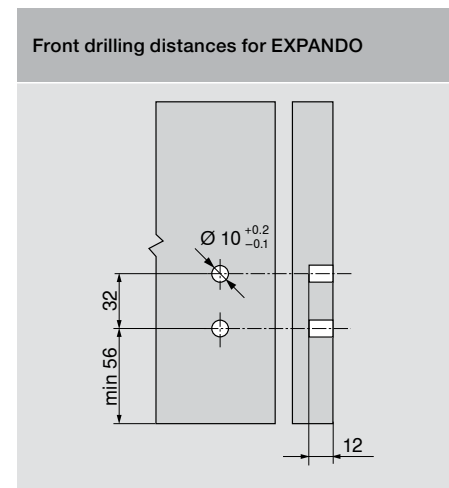
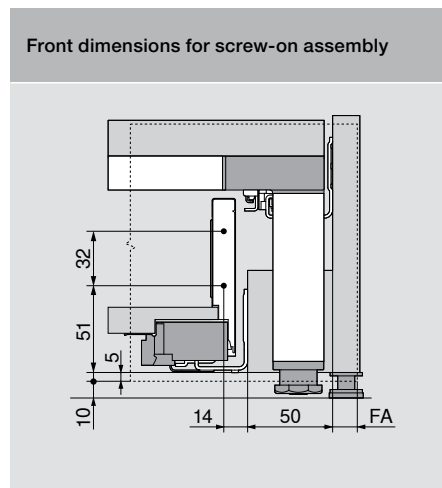
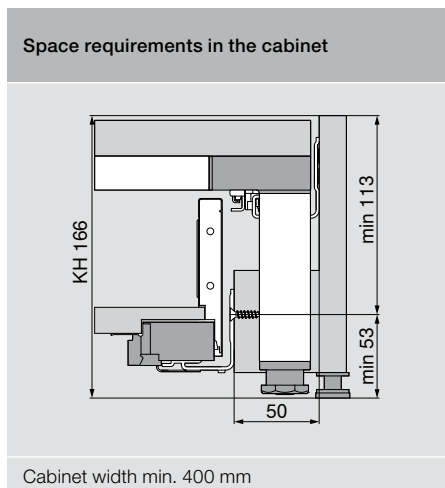

TANDEMBOX – height M

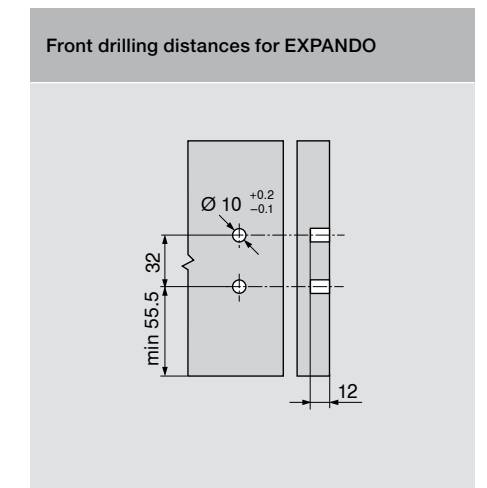
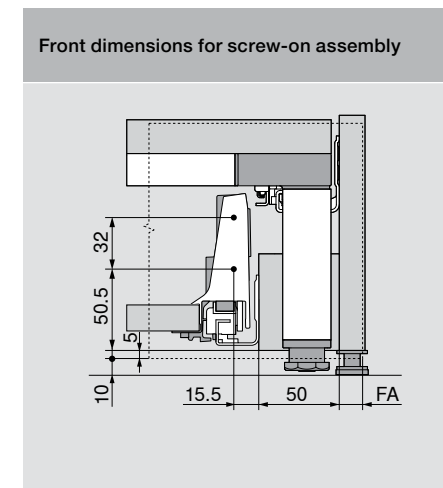
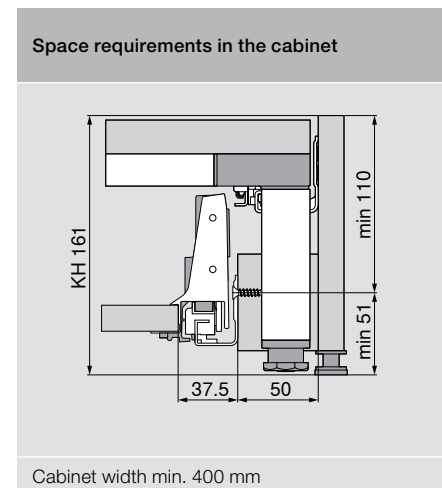

LEGRABOX – height K

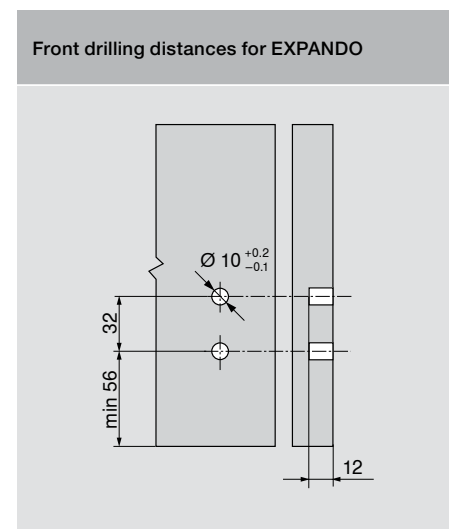
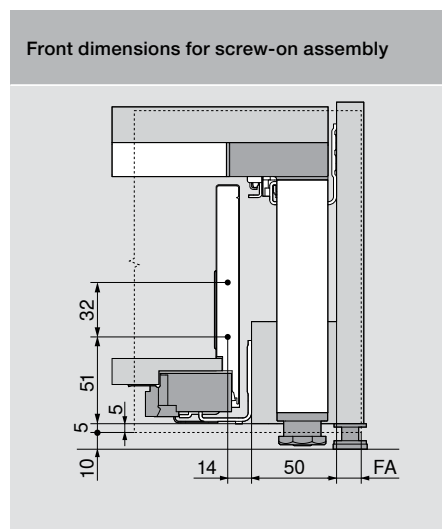
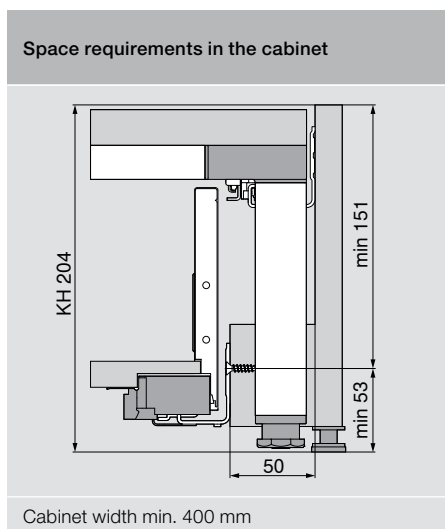

FA Front overlay
KH Cabinet height

FA Front overlay
KH Cabinet height



MOVENTO

Space requirements in the cabinet

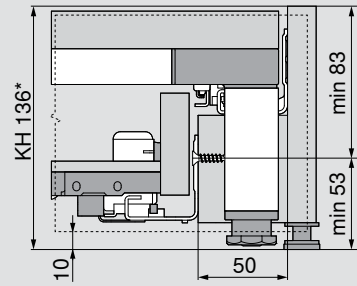

* When using the Blum-spacer strip min. cabinet height KH 148 mm
Cabinet width min. 400 mm, with SERVO-DRIVE min. 450 mm

TANDEM

Space requirements in the cabinet

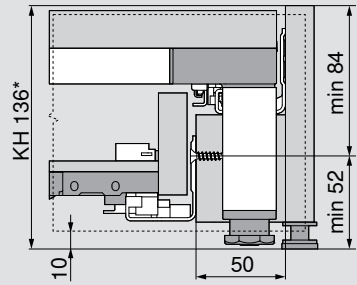

* When using the Blum-spacer strip min. cabinet height KH 148 mm
Cabinet width min. 400 mm, with SERVO-DRIVE min. 450 mm

Dimension - Blum spacer strip

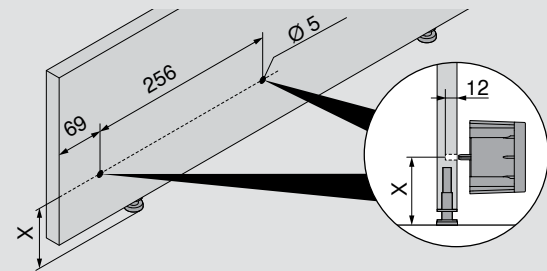

Pull-out systems	X (mm)
LEGRABOX	53
TANDEMBOX	51
MOVENTO / TANDEM	53

Chipboard screws Ø 3.5 x 60 mm or Ø 4 x 60mm

KH Cabinet height

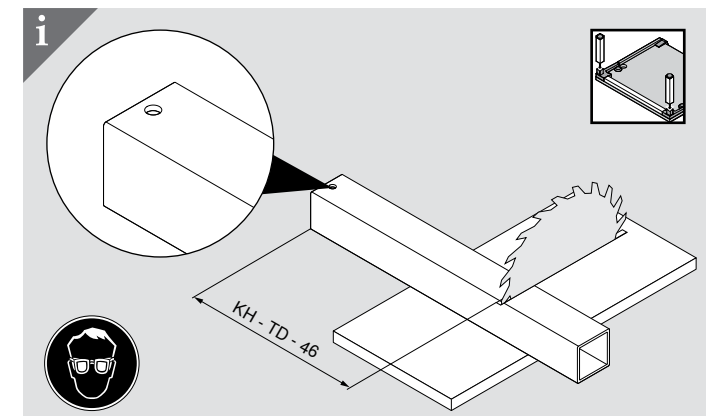
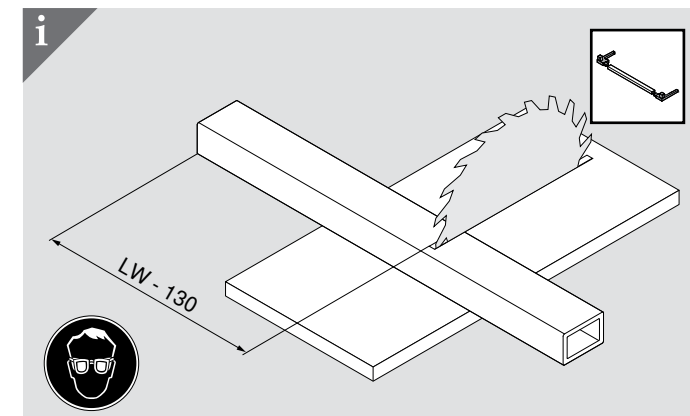
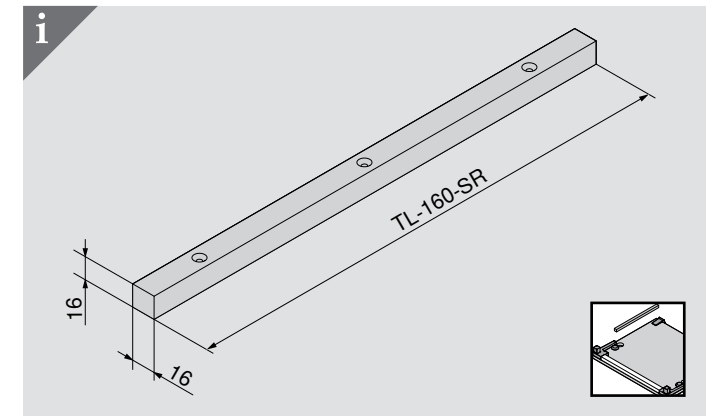
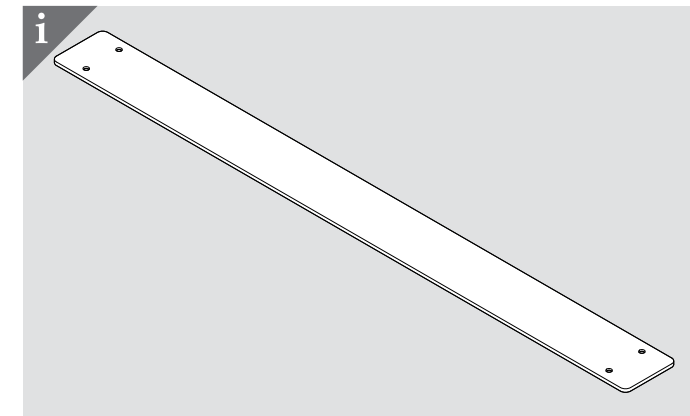
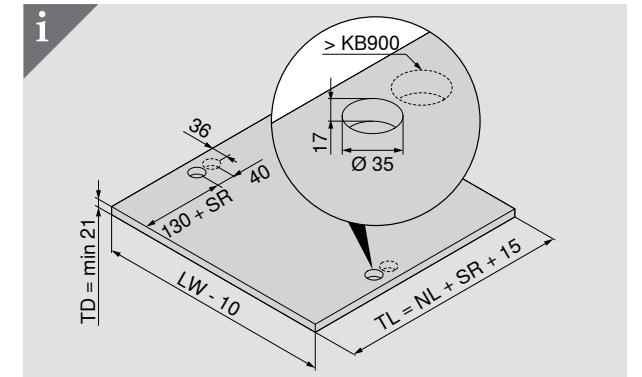
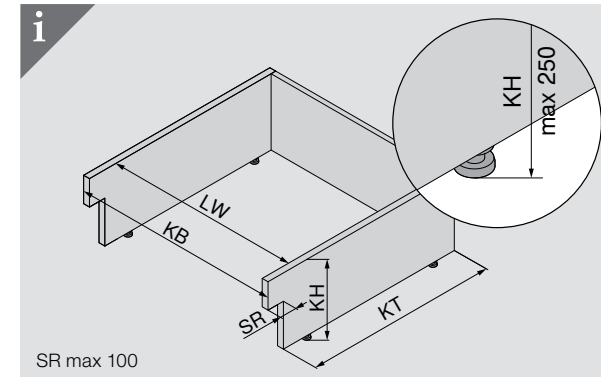
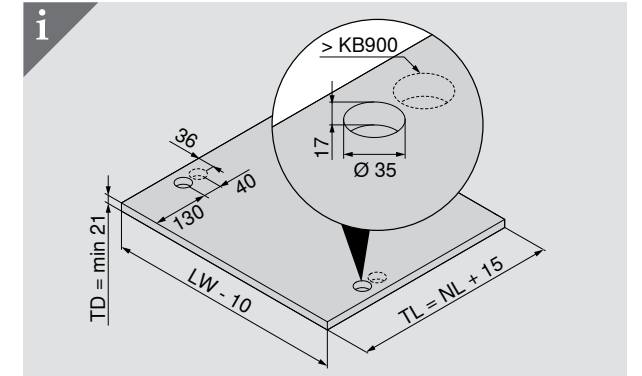
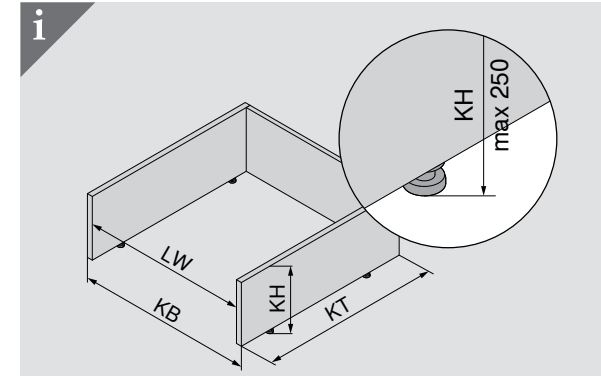
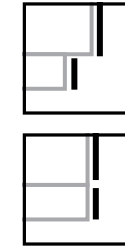

FA Front overlay
KB Cabinet width
KH Cabinet height

KT Cabinet depth
LW Internal cabinet width
NL Nominal length

SR Plinth recess
TD Pull-out shelf base thickness
TL Pull-out shelf length

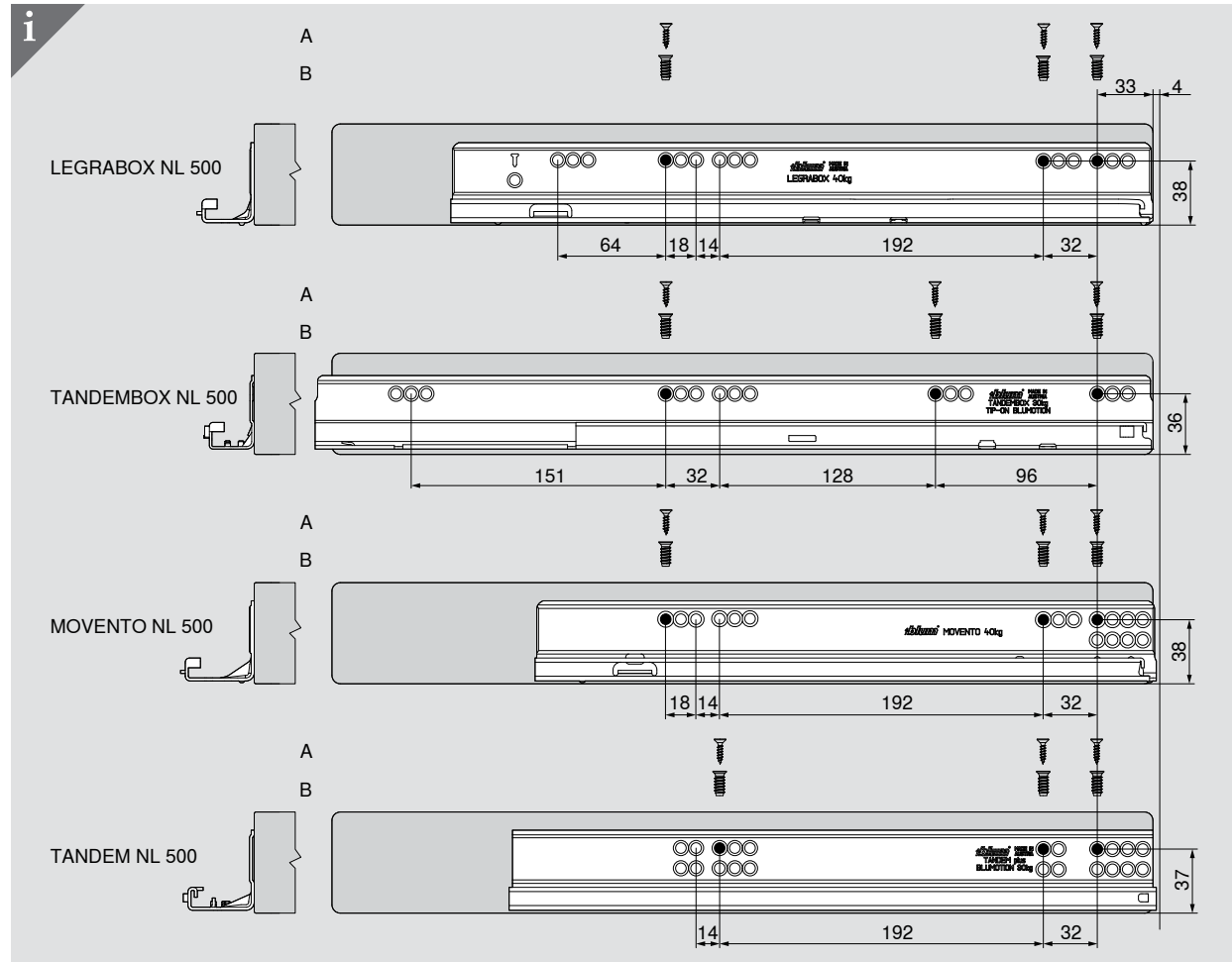
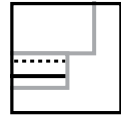
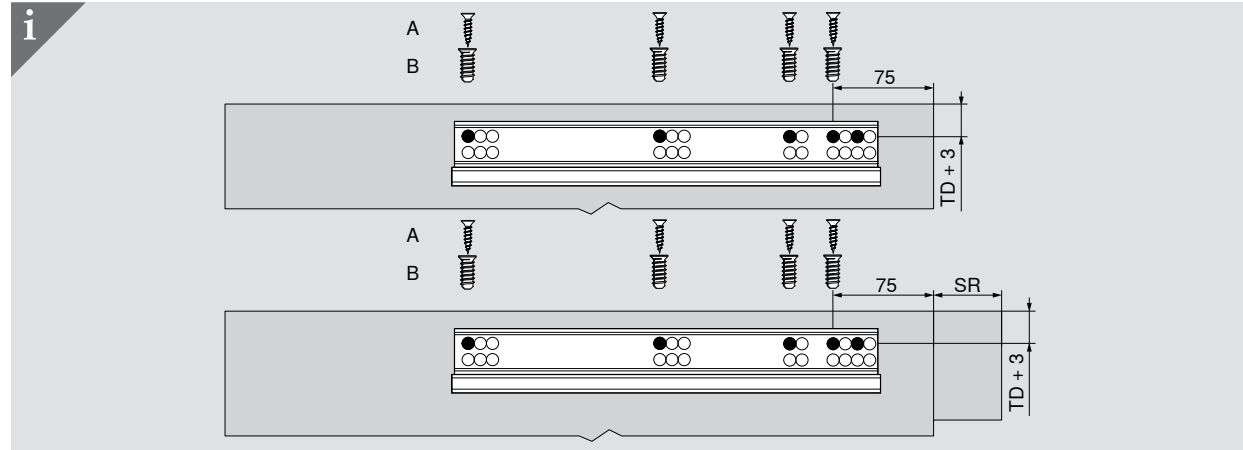
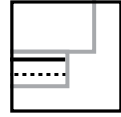

NL ≤ 450	NL 410
NL > 450	NL 460

NL Nominal length
SR Plinth recess
TD Pull-out shelf base thickness

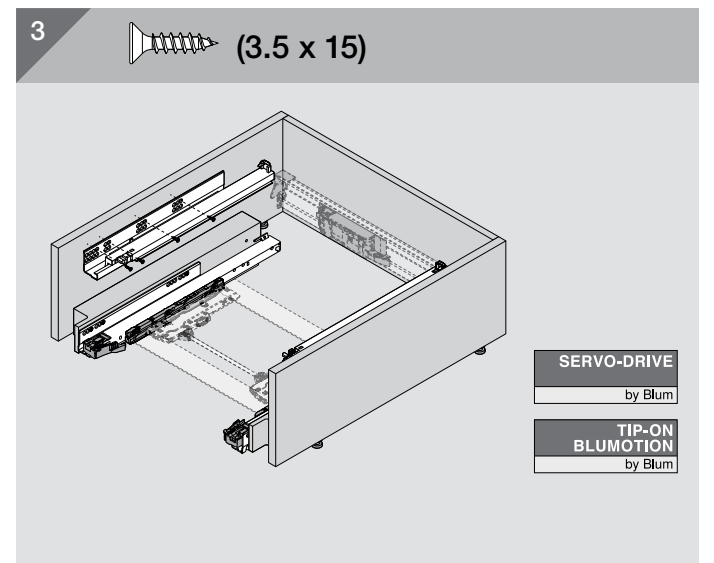
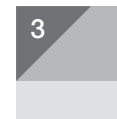
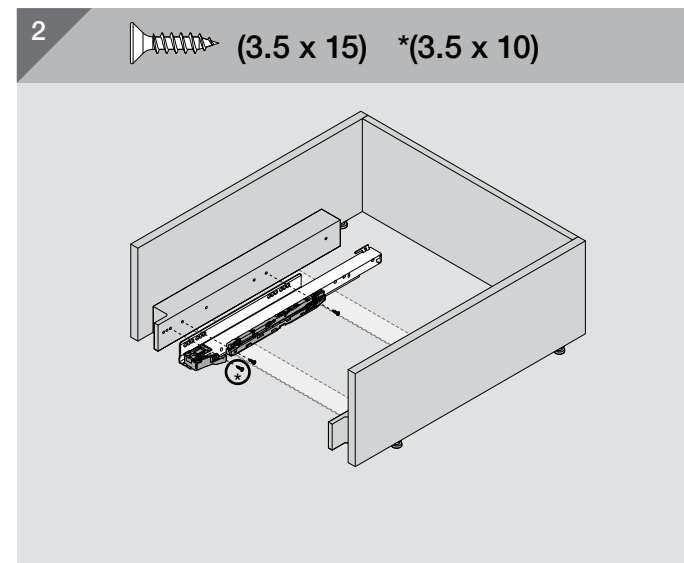
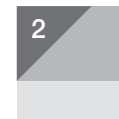
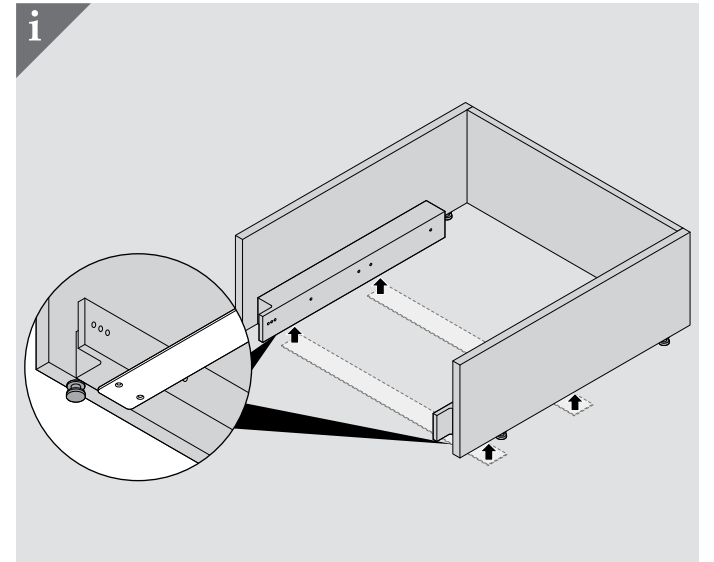
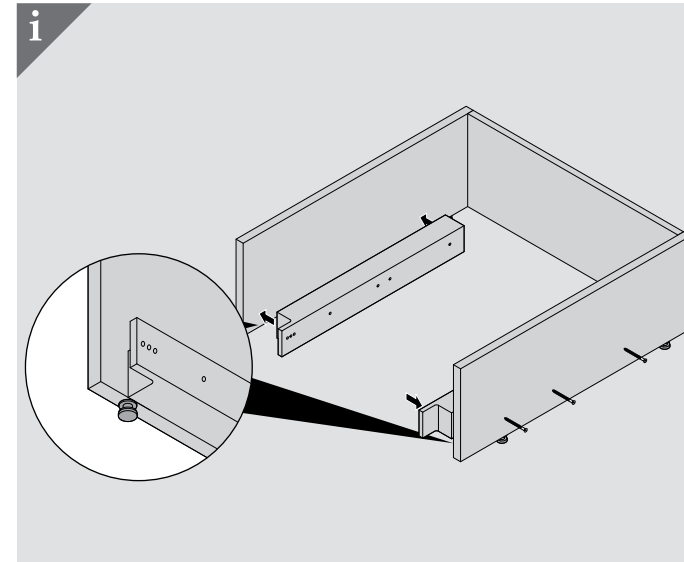
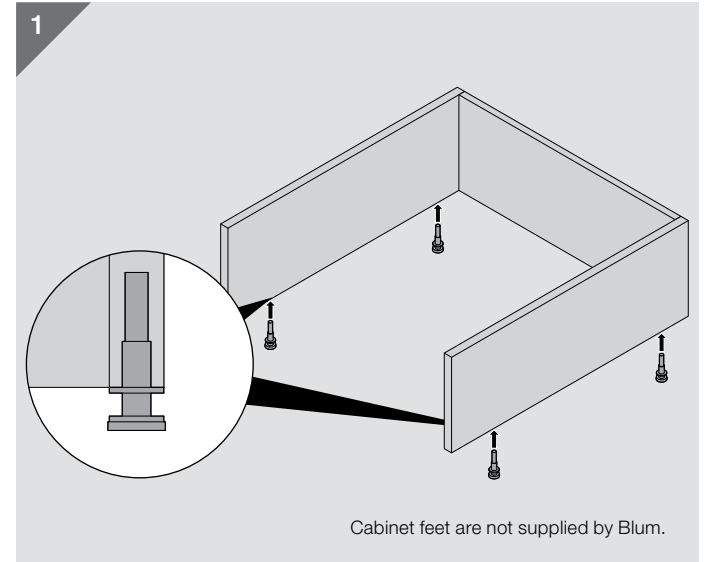
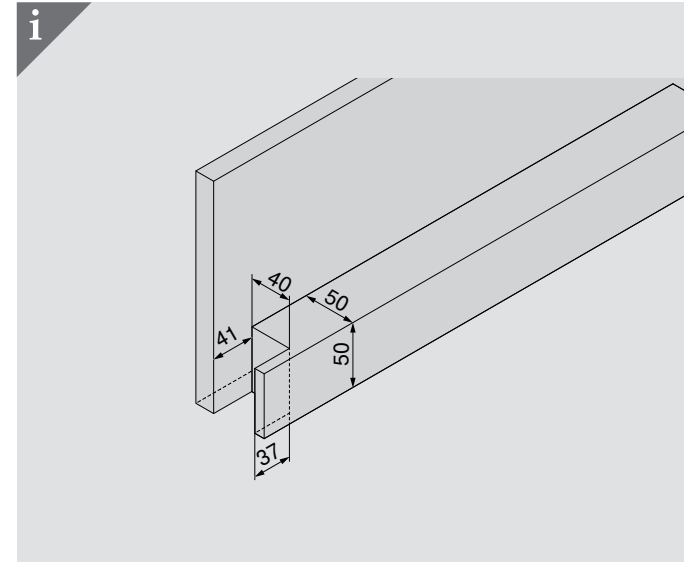

SERVO-DRIVE
by Blum
TIP-ON
BLUMOTION
by Blum

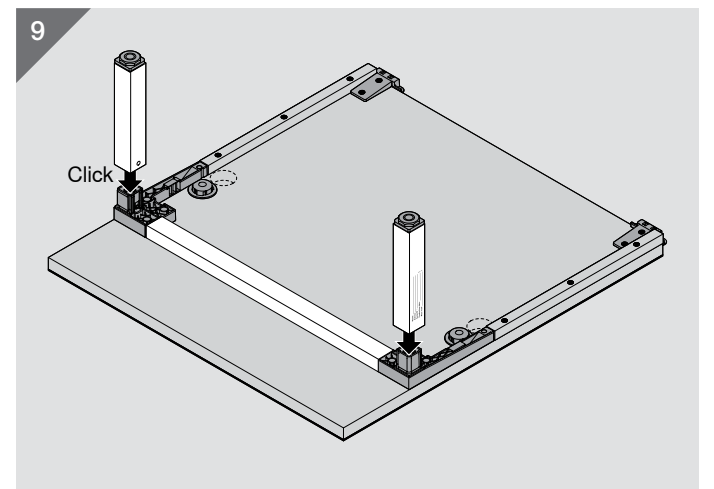
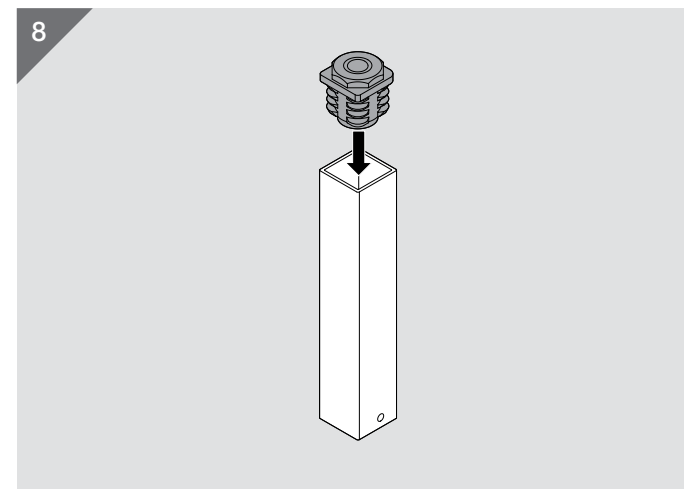
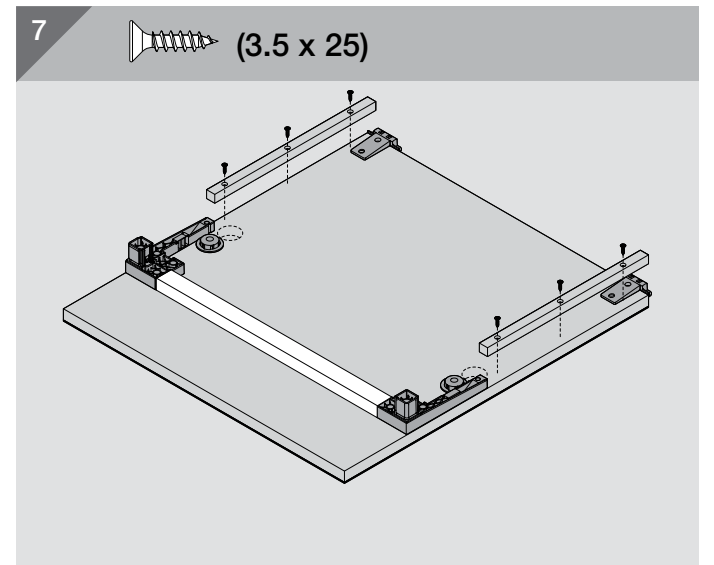
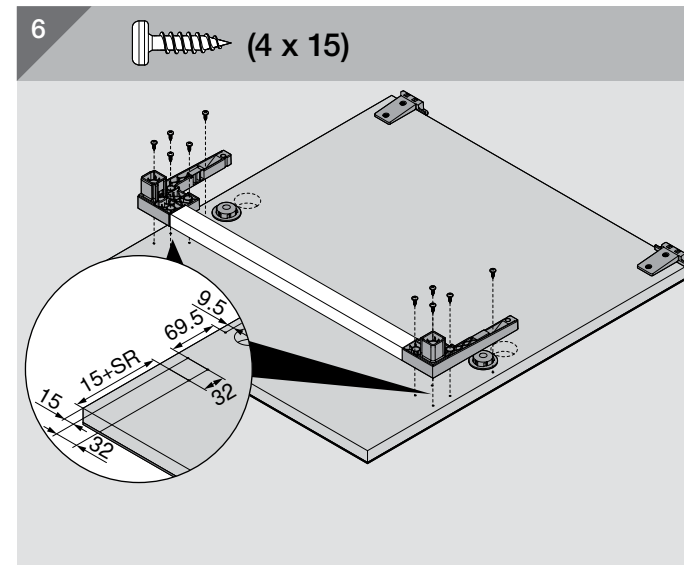
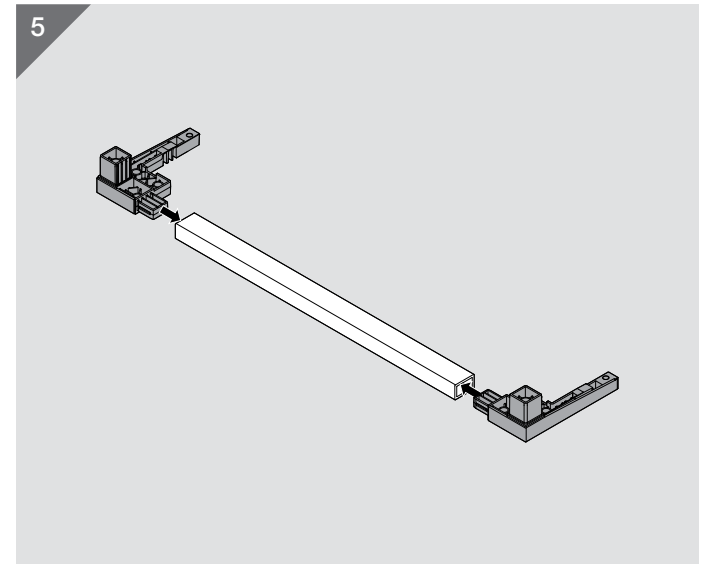
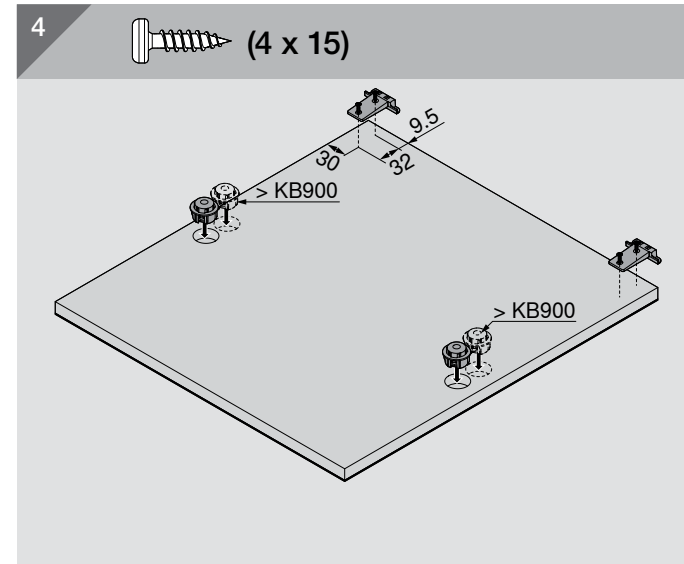
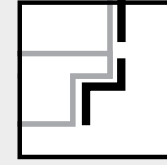
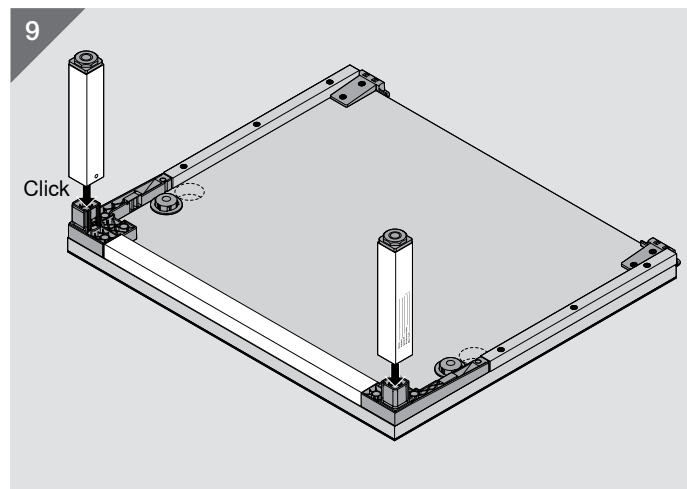
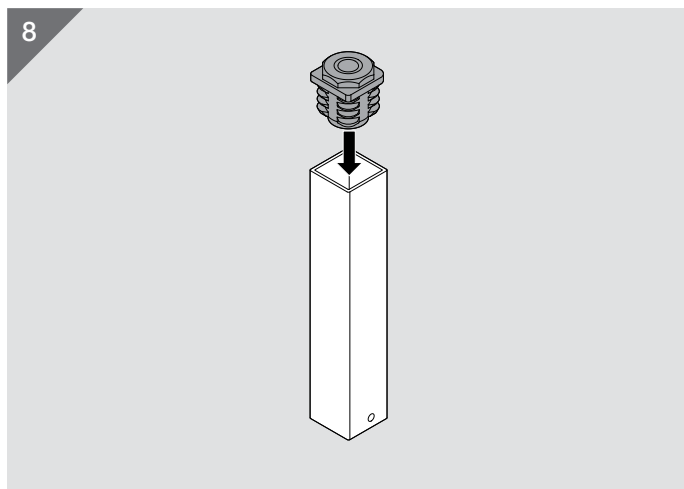
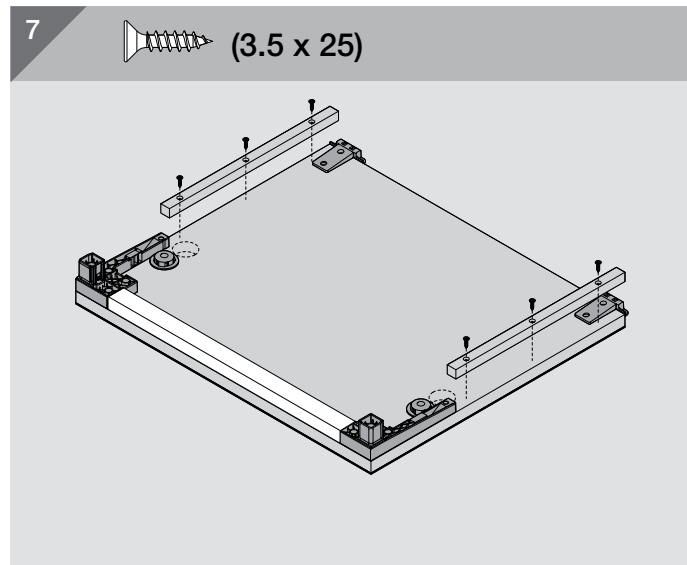
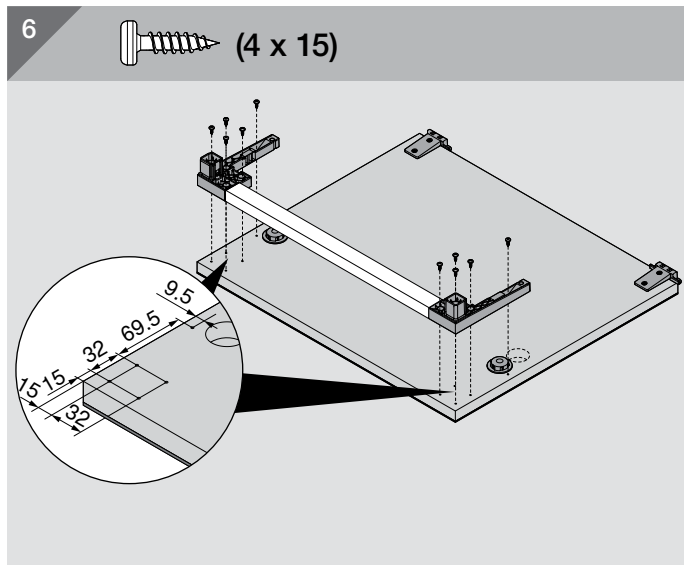
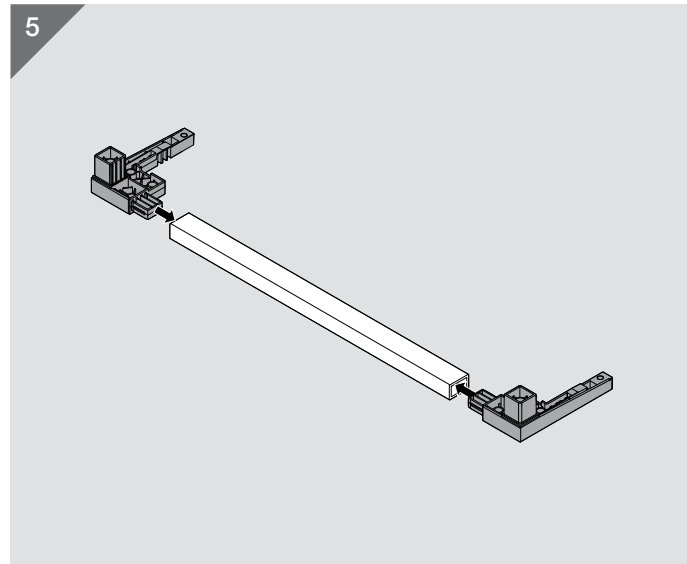
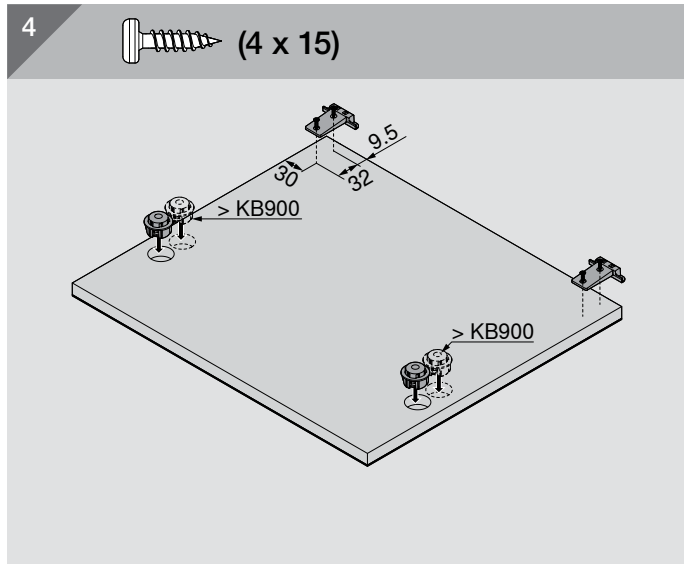
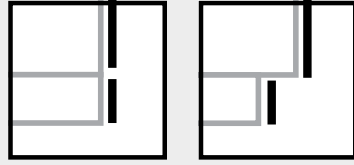

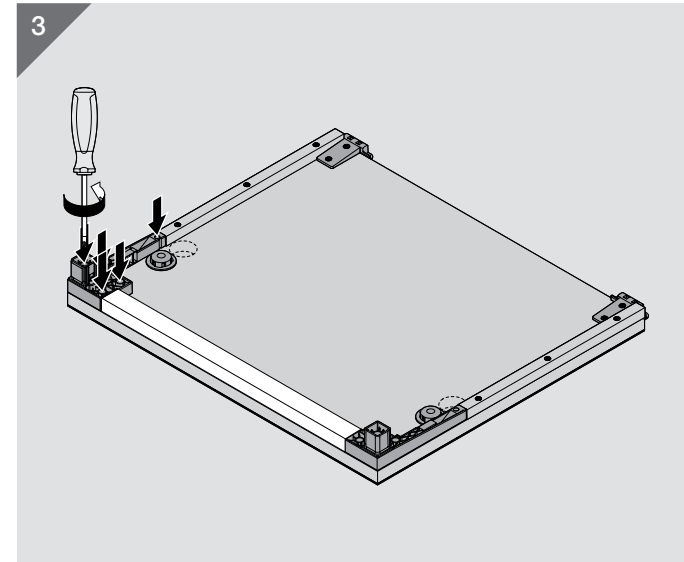
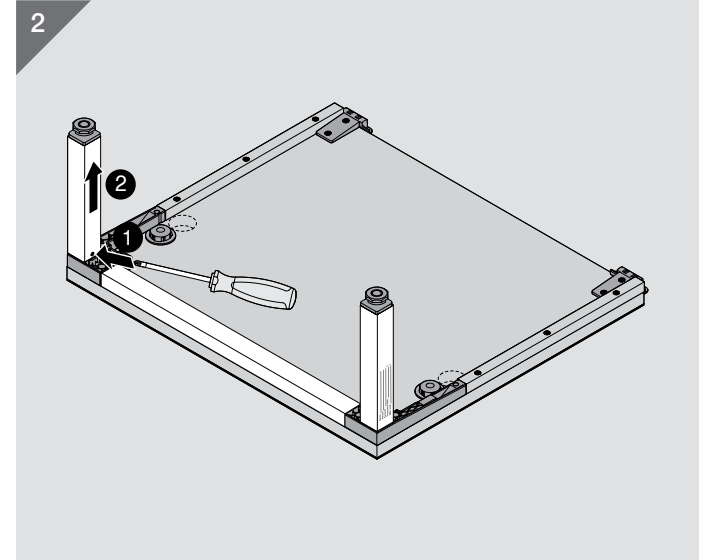
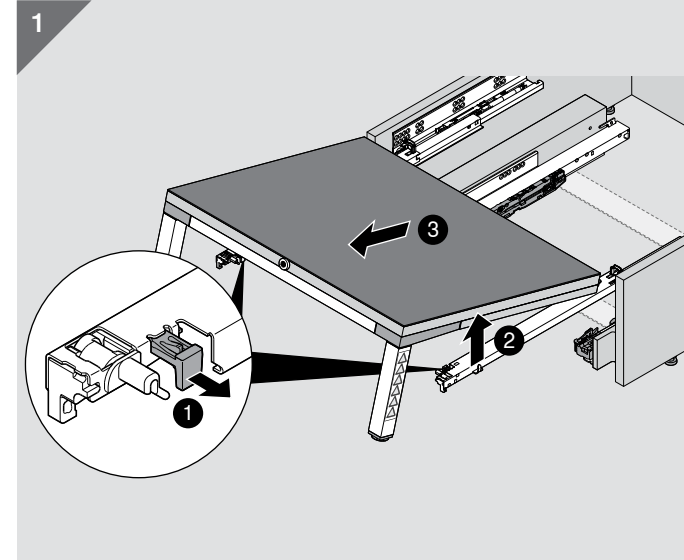
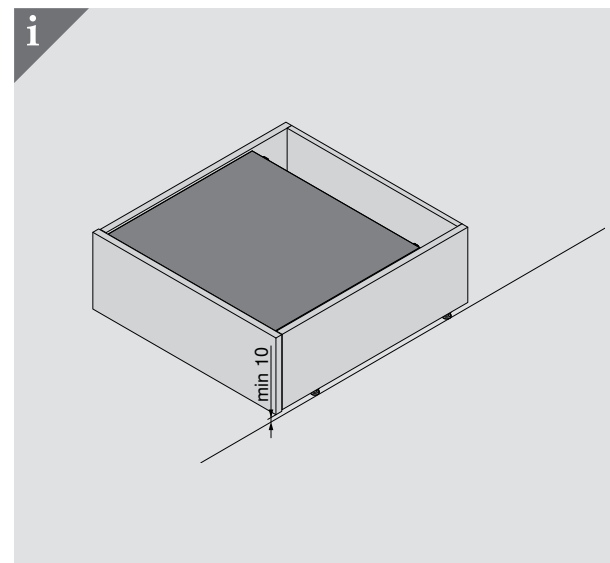
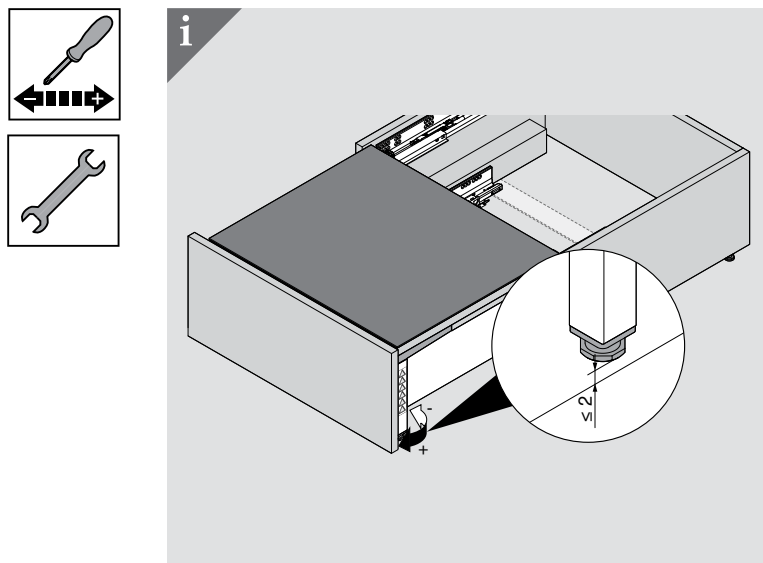
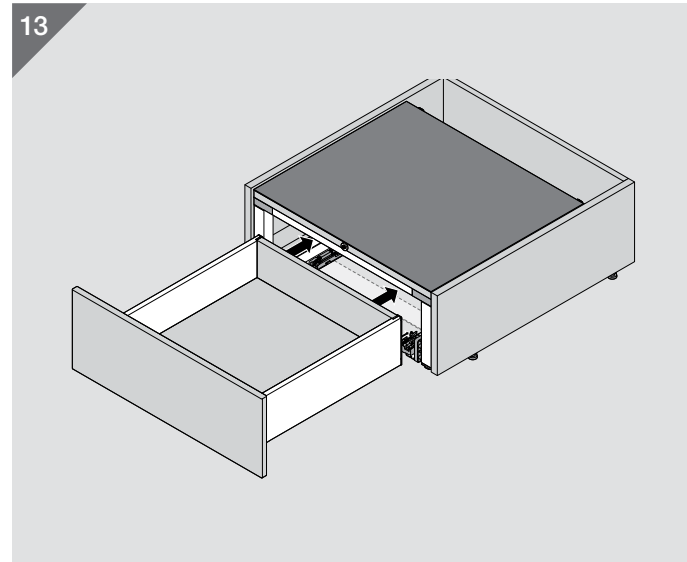
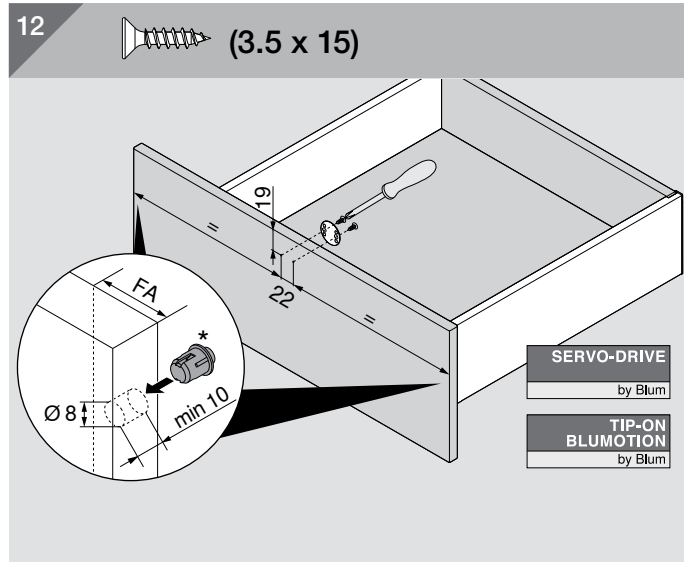
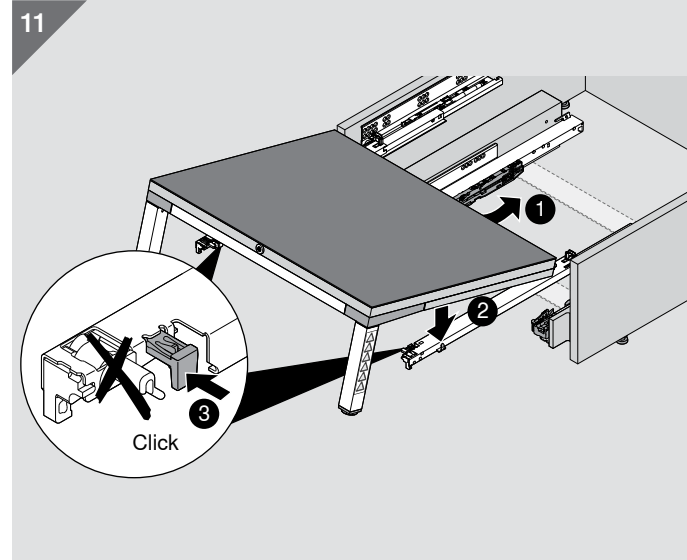
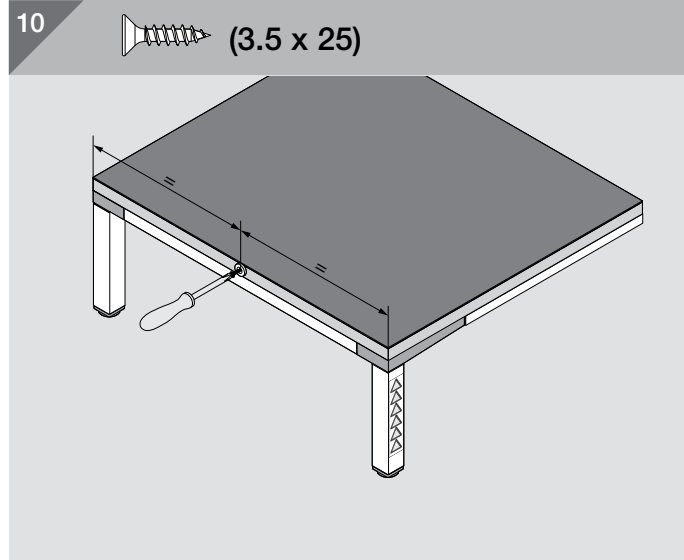



The company Blum

Founded over 60 years ago by Julius Blum, Blum is a family-owned company that operates on an international scale. Its strategic business segments include lift, hinge and pull-out systems. All our product developments focus on perfecting motion.

www.blum.com



Blum in Austria and around the world

The company has eight plants in Vorarlberg, Austria, additional production sites in Poland, the USA and Brazil and 31 subsidiaries/representative offices. Blum supplies more than 120 markets. The Blum Group employs 8,000 people in total, 6,000 of whom work in Vorarlberg.



Global customer benefits

“Whether manufacturer, distributor, fitter or kitchen user – everybody should personally enjoy the benefits of Blum products” – that is Blum’s philosophy on global customer benefits.



Innovations

To support customers with innovative fittings solutions and secure long-term success for the company, we need to consistently invest in research and development, in plants and facilities and in employee training. With more than 2,100 granted patents worldwide, Blum is one of Austria’s most innovative companies.



Quality

Blum’s comprehensive concept of quality does not only apply to products. Services and collaboration with customers and partners should also meet the same quality requirements.



Environment

At Blum, we believe that responsible ecological behaviour has long-term economic benefits. The longevity of products is just one of many important aspects. Other important measures include the use of environmentally-friendly processes, the intelligent use of materials and prudent energy management.



DYNAMIC SPACE

Good workflows, optimum use of storage space and top quality motion are important features of a practical kitchen. Blum’s ideas for practical kitchens are designed to bring function, convenience and ergonomics to furniture interiors.

 Houzz **PRO**:
Blum Australia

 Instagram:
@blumaustralia, #blumaustralia

 Facebook:
facebook.com/blumaustralia

 Android App on Google Play:
Easy Assembly App

 Available on the App Store:
Easy Assembly App

 Tag Us:
#blumaustralia

Blum Showrooms Sydney (Head Office)

10 Blackbird Close
Len Waters Estate NSW 2170
Ph: 02 9612 5400

Adelaide

179 Railway Terrace
Mile End SA 5031
Ph: 08 8118 6070

Brisbane

6/39-45 Compton Road
Underwood QLD 4119
Ph: 07 3135 9490

Melbourne

245 Ferntree Gully Road
Mount Waverley VIC 3149
Ph: 03 9982 1720

Perth

3/425 Scarborough Beach Road
Osborne Park WA 6017
Ph: 08 6467 0110

Blum Australia Pty Ltd
PO BOX 1615
Green Valley, NSW, 2168
Australia
Toll Free: 1800 179 186
E-mail: info.au@blum.com
blum.com

