

# FISHER & PAYKEL

## SPECIFICATION GUIDE

## INTEGRATED DOUBLE DISHDRAWER™ DISHWASHER, TALL, SANITISE

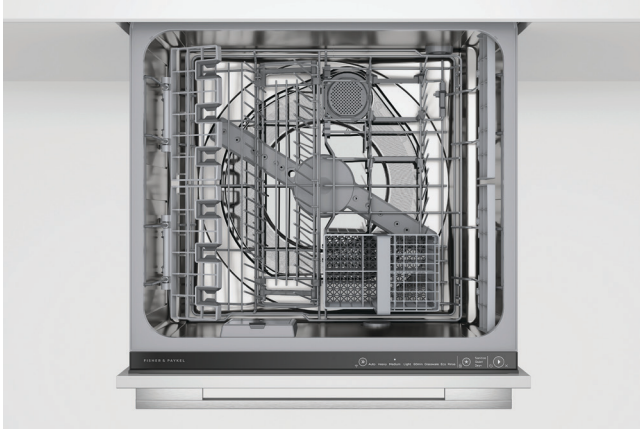

### OVERVIEW

Introducing our new Series 11 DishDrawer™ Dishwasher with stainless steel tub. Designed to blend seamlessly with kitchen cabinetry, this dishwasher is panel ready. Flexible racking allows for adjustments to fit in a variety of dishes. A combination of clever technology and simple mechanics means greater reliability and better wash performance.

### MODELS

#### Integrated Double DishDrawer™ Dishwasher, Tall, Sanitise

DD60DTX6I1

DD60DTX6HI1

### SERIES & STYLE

Series 11

Integrated style

### FEATURES

- ① Ergonomic kitchen drawer design with soft close mechanism and knock-to-pause function
- ② Each drawer operates independently allowing for true half load washes
- ③ Seven place settings per drawer with adjustable racking to fit taller dishes up to 310mm plate size\*
- ④ Built to withstand your wash requirements with easy-to-clean stainless steel interior
- ⑤ Eight wash programs from heavy to light, including auto, 60 minute wash and glassware programs
- ⑥ Quiet, Extra Dry and Sanitise wash modifiers provide extra wash options
- ⑦ Spray arm sensing for a reliable wash
- ⑧ Fan-assisted drying removes moisture from the final rinse leaving your dishes with a dry finish
- ⑨ Improved water and energy performance, delivering a powerful wash with optimal results\*\*
- ⑩ WiFi capable for a greater user experience\*\*\*

\*UK/EU models have six place settings per drawer

\*\*AU/NZ: 4 star energy, 5.5 star water (WELS)

BI/EU: D energy efficiency class

SG: 3 ticks water rating

\*\*\*Not available in China models

### ACCESSORIES

- ① Cutlery basket included

# FISHER & PAYKEL

## SPECIFICATION GUIDE

## INTEGRATED DOUBLE DISHDRAWER™ DISHWASHER, TALL, SANITISE

### SPECIFICATIONS

Model No.	DD60DTX6II, DD60DTX6HI1
Dimensions	H 865-925mm W 599mm D 553mm
Weight	61kg
Electrical	
Supply	220-240V, 50Hz
Service	8.5A
Outlet	3-prong grounding type
Plumbing	
Supply	3/4" BSP (GB20)
Pressure	0.03-1Mpa

### PLUMBING AND ELECTRICAL

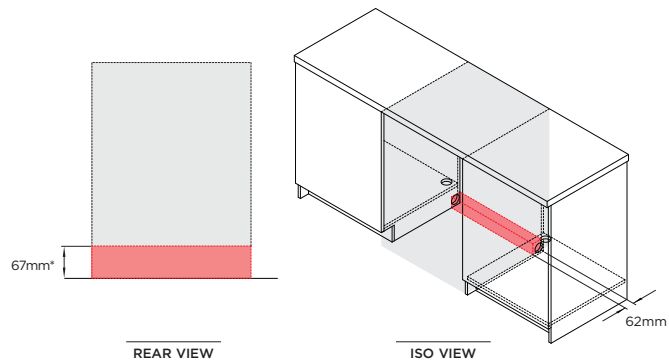

Service outlet at rear extends both sides, hoses and cords can be routed to either or both sides.

\*depending on adjustment of leveling feet

### PRODUCT DIMENSIONS

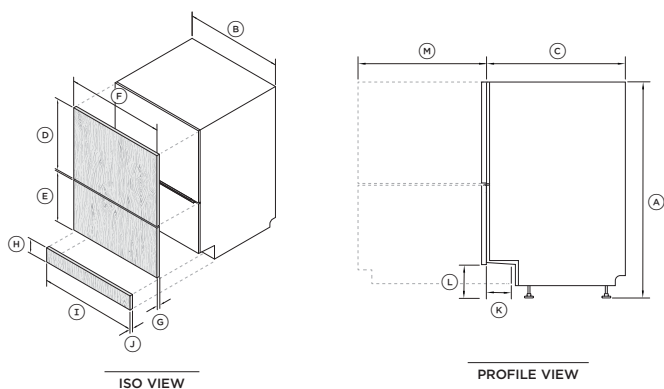

### CAVITY DIMENSIONS: STANDARD INSTALLATION

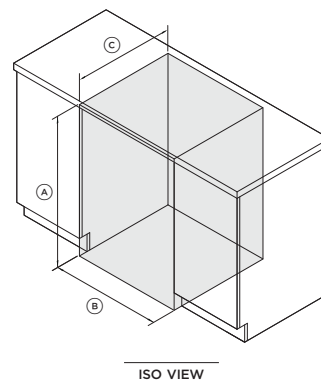

	mm
(A) Overall height*	865-925
(B) Overall width	599
(C) Overall depth**	553
(D) Minimum height of custom upper front panel	442
(E) Height of custom lower front panel	311-360
(F) Width of custom front panels	596-615
(G) Depth of custom front panels	16-20
(H) Height of custom toe kick panel	45-123
(I) Width of custom toe kick panel***	596-615
(J) Minimum depth of custom toe kick panel****	9
(K) Depth of toe kick recess	40-100
(L) Height from floor to custom front panel base*	100-160
(M) Depth of drawer opening**	527

	mm
(A) Minimum inside height*	865
(B) Minimum inside width	600
(C) Minimum inside depth**	579

\*depending on adjustment of levelling feet

\*\*including front panels

\*depending on adjustment of levelling feet

\*\*excluding custom panels and handles

\*\*\*depending on cavity width

\*\*\*\*if using supplied toe kick mounting screws. Panel can be fixed via screwing or gluing to the supplied mounting bracket.