

FISHER & PAYKEL

PRELIMINARY SPECIFICATION GUIDE

FABRIC CARE SERIES 11



OVERVIEW

Care for every corner of the wardrobe with an ecosystem of fabric care products that combine diverse functions to deliver exceptional results. From precision sensing to autonomous technologies, the fabric care suite removes the guesswork, delivering the perfect balance across each product to ensure optimal care for every garment.

PRODUCTS

FC1260HG1 (Graphite), FC1260H1 (White)

Fabric Care Cabinet

WH1160HG1 (Graphite), WH1160H1 (White)

Front Loader Washing Machine, 11kg, ActiveIntelligence™, Steam Care

DH9060HG1 (Graphite), DH9060H1 (White) with interface, Heat Pump Dryer, 9kg, Steam Care, Reversible Door

DH9060H1G1 (Graphite), DH9060H1L1 (White) without interface, Heat Pump Dryer, 9kg, Steam Care, Reversible Door

ACCESSORIES

FM2060SG1 (Graphite), FM2060S1 (White)

Storage Plinth

CA99373(Graphite), CA428159 (White)

Stacking kit

FEATURES

- ① With multiple configurations from compact to large, this modular fabric care solution is designed to work for every space of the evolving home.
- ② From delicates to durables, and everyday to occasional, there is a specialist cycle that ensures optimal care for every type of garment.
- ③ Centralised control of the entire laundry suite with seamless product-to-product communication, all from one intuitive touchscreen and the SmartHQ™ app.
- ④ Featuring a range of specialised environments and cycles, designed to lengthen the life of a garment and care for them with minimal environmental impact.
- ⑤ Timeless in design, the fabric care suite is engineered with premium materials and precise manufacturing, enabling long-lasting care for both product and garment.

FISHER & PAYKEL

PRELIMINARY SPECIFICATION GUIDE

FABRIC CARE SERIES 11

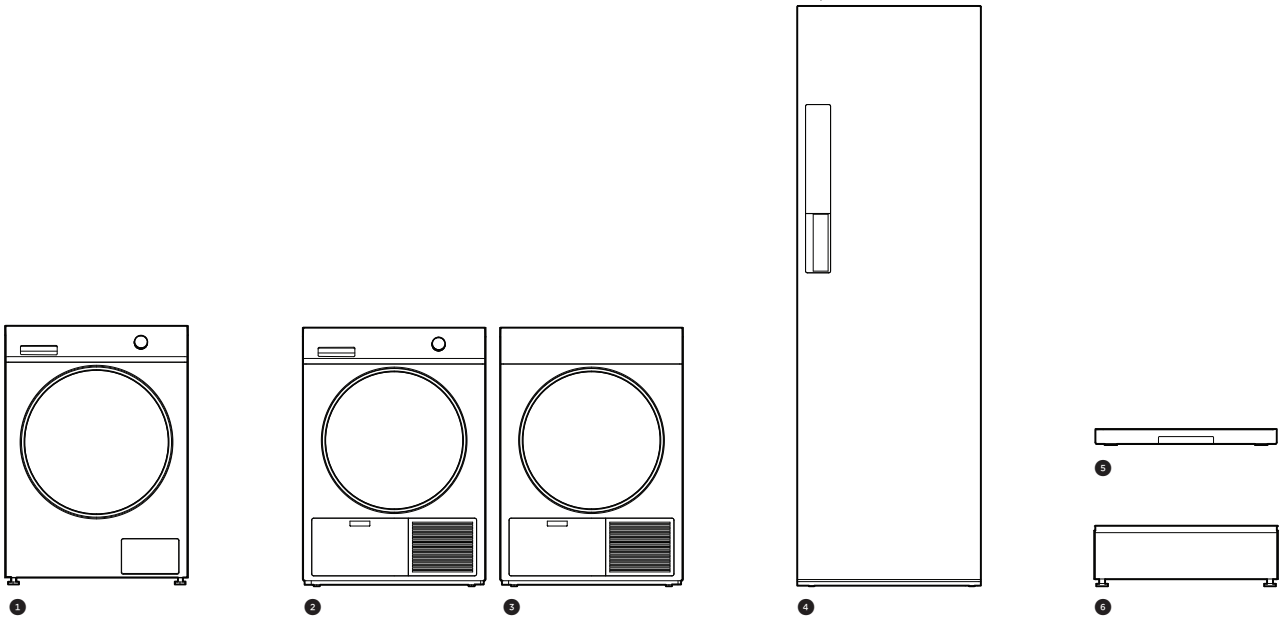

PRODUCT OVERVIEW

1 WH1160HG1 (Graphite), WH1160H1 (White)
Front Loader Washing Machine, 11kg, ActiveIntelligence™, Steam Care

2 DH9060HG1 (Graphite), DH9060H1 (White)
With interface
Heat Pump Dryer, 9kg, Steam Care, Reversible Door

3 DH9060HLG1 (Graphite), DH9060HL1 (White)
Without interface
Heat Pump Dryer, 9kg, Steam Care, Reversible Door

4 FC1260HG1 (Graphite), FC1260H1 (White)
Fabric Care Cabinet

5 CA99373 (Graphite), CA428159 (White)
Stacking kit

6 FM2060SG1 (Graphite), FM2060S1 (White)
Storage plinth

FISHER & PAYKEL

PRELIMINARY SPECIFICATION GUIDE

FABRIC CARE SERIES 11

CONFIGURATIONS

1 SIDE BY SIDE

WH1160HG1, WH1160H1

Front Loader Washing Machine

DH9060HG1, DH9060H1 (with interface)

Heat Pump Dryer

FC1260HG1, FC1260H1

Fabric Care Cabinet

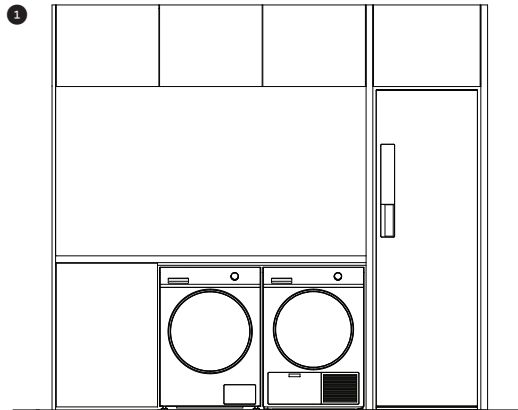

2 SIDE BY SIDE WITH PLINTHS

WH1160HG1, WH1160H1

Front Loader Washing Machine

DH9060HG1, DH9060H1 (with interface)

Heat Pump Dryer

FM2060SG1, FM2060S1

Storage Plinth x 2

FC1260HG1, FC1260H1

Fabric Care Cabinet

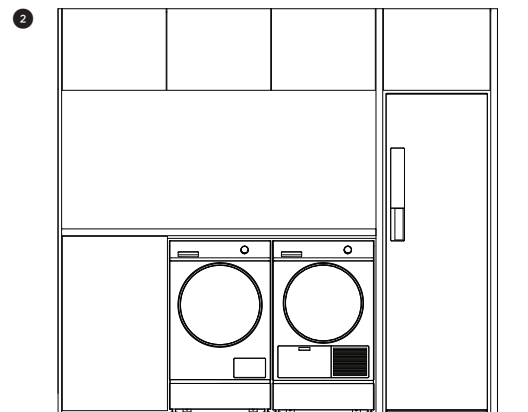

3 STACKED

WH1160HG1, WH1160H1

Front Loader Washing Machine

DH9060H1G1, DH9060H1L1 (without interface*)

Heat Pump Dryer

FM2060SG1, FM2060S1

Storage Plinth

CA99373, CA428159

Staking Kit

FC1260HG1, FC1260H1

Fabric Care Cabinet

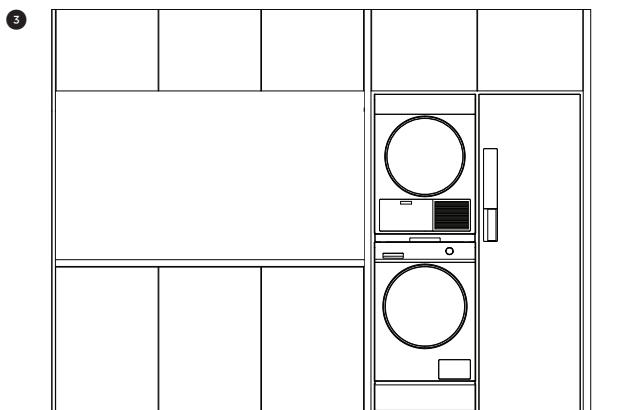

*Heat Pump controlled through Washer interface

FISHER & PAYKEL

PRELIMINARY SPECIFICATION GUIDE

FABRIC CARE SERIES 11

SPECIFICATIONS	
Configuration	SIDE BY SIDE
Models	WH1160HG1/WH1160H1, DH9060HG1/DH9060H1 and FC1260HG1/FC1260H1
Electrical	
Supply	220 - 240V, 50Hz
Service	10 Amps circuit per product
Outlet	3-prong grounding-type
Plumbing	Only for WH1160HG1, WH1160H1, DH906HG1 and DH9060H1 models
Supply	Hose set provided
Pressure	Max. 1MPa (150psi); Min. 50KPa (7psi); Min 6 litres/min

PRODUCT DIMENSIONS

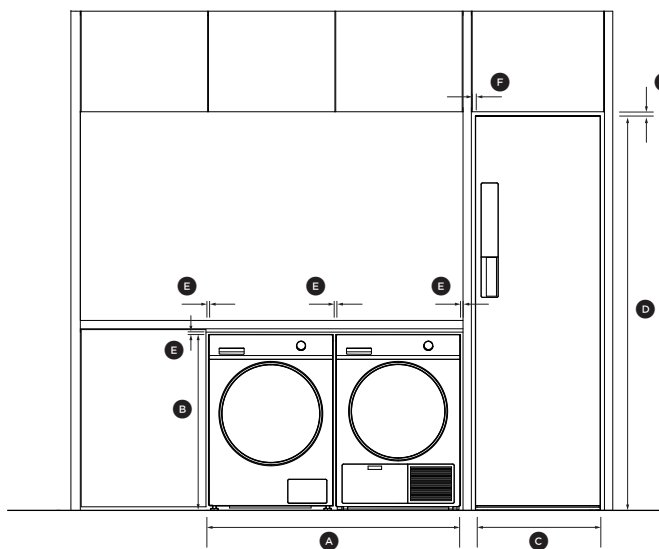

FRONT VIEW

CAVITY DIMENSIONS

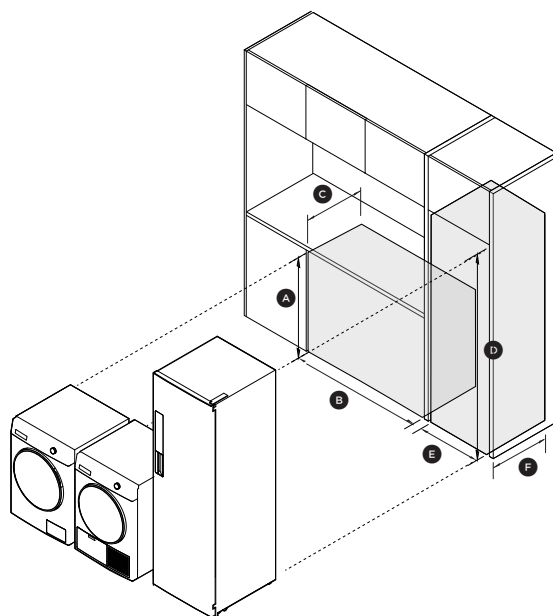

ISO VIEW

	mm
(A) Overall width Washer and Dryer	1220
(B) Overall height Washer and Dryer	850
(C) Overall width Fabric Care Cabinet	600
(D) Overall height Fabric Care Cabinet	1900
(E) Gap surrounding Washer and Dryer	12
(F) Gap surrounding Fabric Care Cabinet	20

Washer + Dryer	mm
(A) Overall height	862
(B) Overall width	1252
(C) Overall depth	700
Fabric Cabinet	mm
(D) Overall height	1920
(E) Overall width	640
(F) Overall depth	700

FISHER & PAYKEL

PRELIMINARY SPECIFICATION GUIDE

FABRIC CARE SERIES 11

SPECIFICATIONS

Configuration	SIDE BY SIDE WITH PLINTHS
Models	WH1160HG1/WH1160H1, DH9060HG1/DH9060H1, FC1260HG1/FC1260H1 and FM2060SG1/FM2060S1
Electrical	
Supply	220 - 240V, 50Hz
Service	10 Amps circuit per product
Outlet	3-prong grounding-type
Plumbing	Only for WH1160HG1, WH1160H1, DH906HG1 and DH9060H1 models
Supply	Hose set provided
Pressure	Max. 1MPa (150psi); Min. 50KPa (7psi); Min 6 litres/min

PRODUCT DIMENSIONS

CAVITY DIMENSIONS

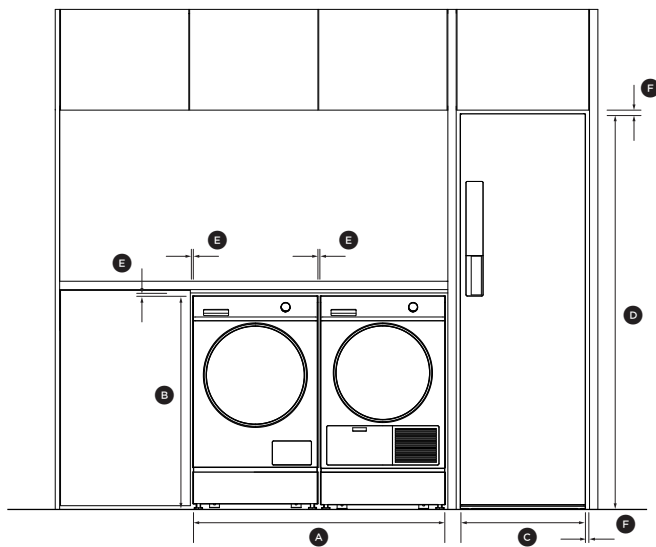

FRONT VIEW

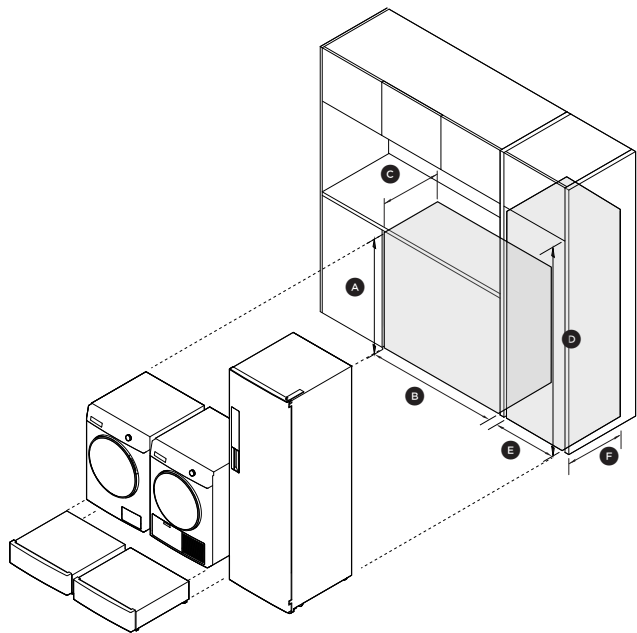

ISO VIEW

	mm
(A) Overall width Washer, Dryer and Plinth	1220
(B) Overall height Washer, Dryer and Plinth	1030
(C) Overall width Fabric Care Cabinet	600
(D) Overall height Fabric Care Cabinet	1900
(E) Gap surrounding Washer and Dryer	12
(F) Gap surrounding Fabric Care Cabinet	20

Washer + Dryer	mm
(A) Overall height	1040
(B) Overall width	1252
(C) Overall depth	700
Fabric Care Cabinet	mm
(D) Overall height	1920
(E) Overall width	640
(F) Overall depth	700

FISHER & PAYKEL

PRELIMINARY SPECIFICATION GUIDE

FABRIC CARE SERIES 11

SPECIFICATIONS	
Configuration	STACKED
Models	WH1160HG1/WH1160H1, DH9060HG1/DH9060H1, FC1260HG1/FC1260H1, FM2060SG1/FM2060S1 and CA99373/ CA428159
Electrical	
Supply	220 - 240V, 50Hz
Service	10 Amp circuit per product
Outlet	3-prong grounding-type
Plumbing	Only for WH1160HG1, WH1160H1, DH906HG1 and DH9060H1 models
Supply	Hose set provided
Pressure	Max. 1MPa (150psi); Min. 50KPa (7psi); Min 6 litres/min

PRODUCT DIMENSIONS

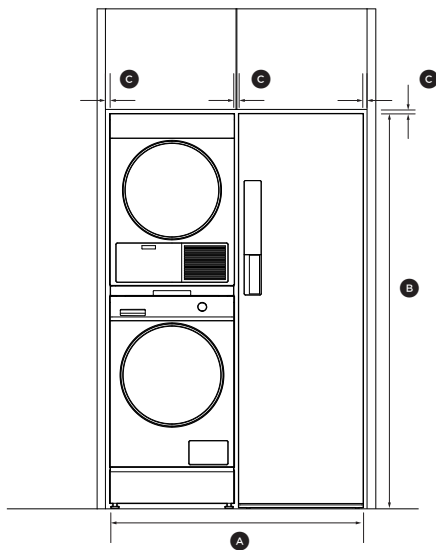

FRONT VIEW

CAVITY DIMENSIONS

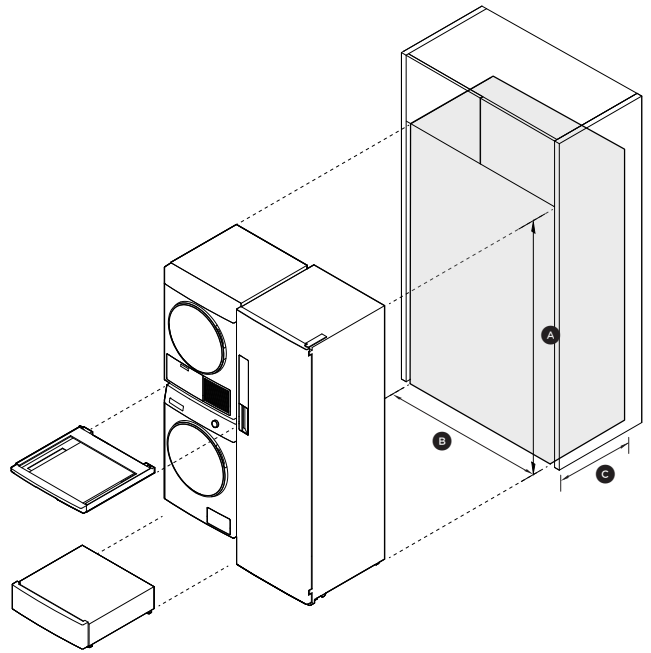

ISO VIEW

	mm
(A) Overall width Washer, Dryer, Stacking Kit, Plinth and Fabric Care Cabinet	1220
(B) Overall height Washer, Dryer, Stacking Kit, Plinth and Fabric Care Cabinet	1900
(C) Gap surrounding Washer, Dryer, Stacking Kit, Plinth and Fabric Care Cabinet	20

All models	mm
(A) Overall height	1920
(B) Overall width	1260
(C) Overall depth	700

FISHER & PAYKEL

PRELIMINARY SPECIFICATION GUIDE

FRONT LOADER WASHING MACHINE SERIES 11

SPECIFICATION

Model No.	WH1160H1, WH1160HG1
Dimensions	H 845mm W 600mm D 665mm
Weight	82kg
Electrical	
Supply	220-240V, 50Hz
Service	10 Amps
Outlet	3-prong grounding-type
Plumbing	
Supply	Hose set provided
Pressure	Max. 1MPa (150psi); Min. 50KPa (7psi); Min 6 litres/min

PRODUCT DIMENSIONS

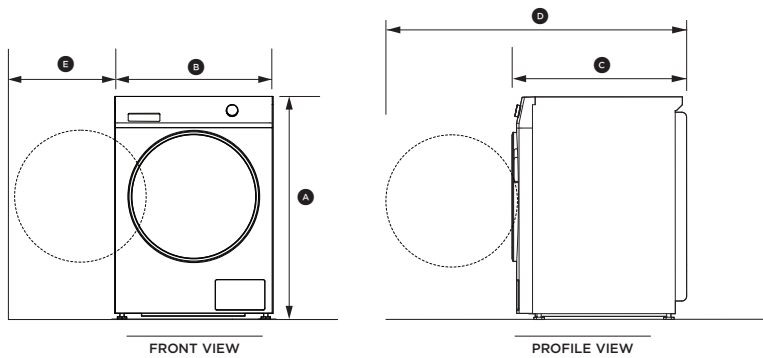

CAVITY DIMENSIONS: STANDARD INSTALLATION

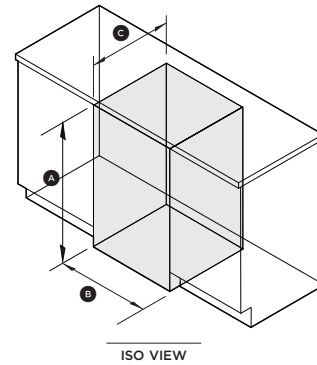

	mm
(A) Overall height*	min 845 max 860
(B) Overall width	600
(C) Overall depth**	665
(D) Depth with the door open	1080
(E) Door clearance to adjacent wall	min 355

* Includes adjustable mounted feet and the range of movement from those shown. This PSG is superseded and will become obsolete upon launch of the product. This PSG should not be used as installation guidance for any product. Further information is required to safely and correctly install the products featured here. Specific installation guidance will be available with the product on delivery and on our website fisherpaykel.com

** Includes dial and door when closed

	mm
(A) Minimum height*	857
(B) Minimum width	624
(C) Minimum overall cavity depth	
• Flush with front panel of the product	665
• In cupboard	725
Minimum gap clearance to adjacent product or cabinetry**	12

* Depends on feet adjustment

** Applies to sides and top

FISHER & PAYKEL

PRELIMINARY SPECIFICATION GUIDE

HEAT PUMP DRYER SERIES 11

SPECIFICATIONS

Model No.	DH9060H1, DH9060HG1
Dimensions	H 840mm W 600mm D 655mm
Weight	53kg
Electrical	
Supply	220-240V, 50Hz
Service	10 Amps
Outlet	3-prong grounding-type
Plumbing	
Supply	Hose set provided
Pressure	Max. 1MPa (150psi); Min. 50KPa (7psi); Min 6 litres/min

PRODUCT DIMENSIONS

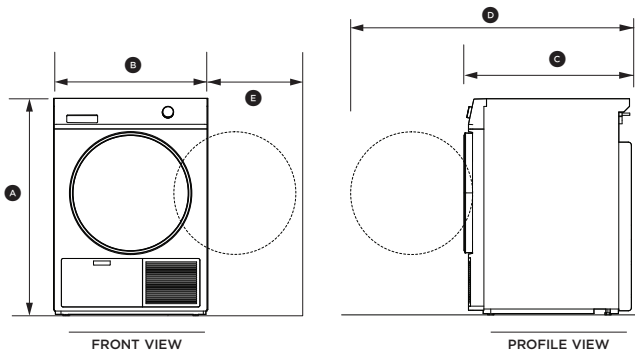

	mm
(A) Overall height*	min 840 max 855
(B) Overall width	600
(C) Overall depth**	655
(D) Depth with the door open***	1080
(E) Door clearance to adjacent wall***	min 344

* Includes adjustable mounted feet and the range of movement

** Includes dial and door when closed

***Left hinge and right hinge capable

CAVITY DIMENSIONS: STANDARD INSTALLATION

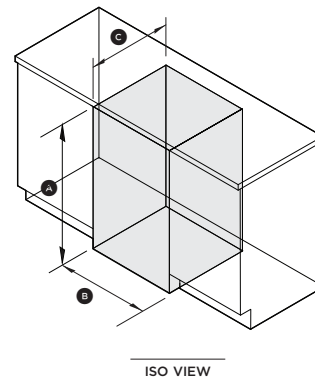

	mm
(A) Minimum height*	852
(B) Overall width	624
(C) Overall cavity depth	
• Flush with front panel of the product	650
• In cupboard	715
Minimum gap clearance to adjacent product or cabinetry**	12

* Depends on feet adjustment

** Applies to sides and top

FISHER & PAYKEL

PRELIMINARY SPECIFICATION GUIDE

HEAT PUMP DRYER SERIES 11

SPECIFICATIONS

Model No.	DH9060HL1, DH9060HLG1
Dimensions	H 840mm W 600mm D 655mm
Weight	53kg
Electrical	
Supply	220-240V, 50Hz
Service	10 Amps
Outlet	3-prong grounding-type
Plumbing	
Supply	Hose set provided
Pressure	Max. 1MPa (150psi); Min. 50KPa (7psi); Min 6 litres/min

PRODUCT DIMENSIONS

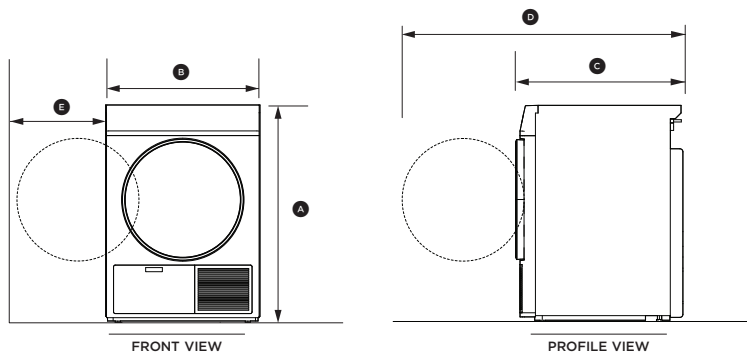

CAVITY DIMENSIONS: STANDARD INSTALLATION

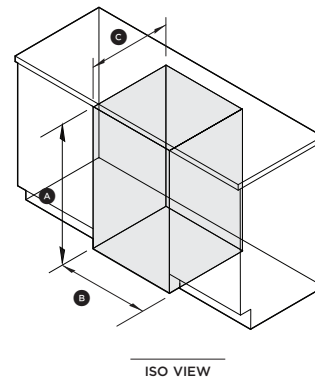

	mm
(A) Overall height*	min 840 max 855
(B) Overall width	600
(C) Overall depth**	655
(D) Depth with the door open***	1080
(E) Door clearance to adjacent wall***	min 344

* Includes adjustable mounted feet and the range of movement

** Includes door when closed

***Left hinge and right hinge capable

	mm
(A) Minimum height*	852
(B) Overall width	624
(C) Overall cavity depth	
• Flush with front panel of the product	650
• In cupboard	715
Minimum gap clearance to adjacent product or cabinetry**	12

* Depends on feet adjustment

** Applies to sides and top

FISHER & PAYKEL

PRELIMINARY SPECIFICATION GUIDE

FABRIC CARE CABINET SERIES 11

SPECIFICATIONS

Model No.	FC1260HG1, FC1260H1
Dimensions	H 1900mm W 600mm D 700mm
Weight	130kg
Electrical	
Supply	220 - 240V, 50Hz
Service	10 Amps
Outlet	3-prong grounding-type

PRODUCT DIMENSIONS

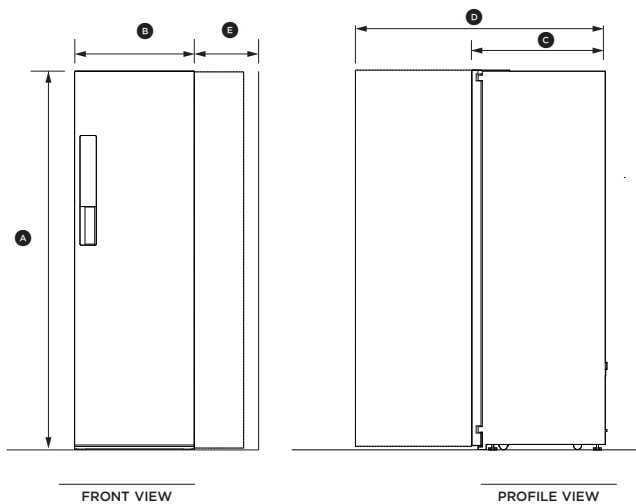

CAVITY DIMENSIONS: STANDARD INSTALLATION

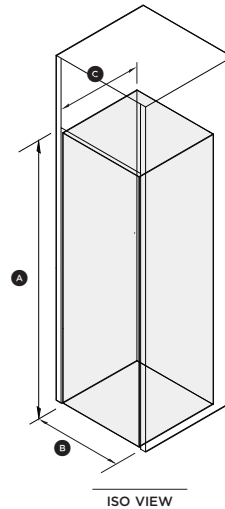

	mm
(A) Overall height*	min 1895 max 1905
(B) Overall width	600
(C) Overall depth	700
(D) Depth with the door open	1285
(E) Door clearance to adjacent wall	min 235

* Includes adjustable mounted feet and the range of movement

	mm
(A) Minimum height*	1915
(B) Overall width	640
(C) Overall cavity depth	700
Minimum gap clearance to adjacent product or cabinetry**	20

* Depends on feet adjustment

** Applies to sides and top