



GOOD. BETTER. BEST.

# FURPHY BARBECUES

*"ENGINEERED FOR PUBLIC USE"*

Everything about Furphy Barbecues from frame to hot plate sizzles with durability, efficiency, easy cleaning, low maintenance – and a great feed in the park!



AUSTRALIAN MADE  
+ 150 YEARS



[www.furphyfoundry.com.au](http://www.furphyfoundry.com.au)



GOOD. BETTER. BEST.

.....

*For over 150 years, Furphy Foundry has created products that are trusted. Be it agricultural equipment or the famous Furphy water cart used by Australian soldiers, through to various cooking products, and in recent decades street and park furniture, Furphy products have become widely regarded as superior in terms of innovation, durability and functionality.*

.....



.....  
*Made in Australia by Australians,  
with a range of optional features,  
our barbecues can be adapted to  
suit any location - from salt-aired  
coastal landscapes to the wide  
open spaces of regional Australia.*  
.....



# THE QUINTESSENTIAL AUSTRALIAN COMMUNITY BARBECUE IS HERE!

Furphy Barbecues are the quintessential Australian design for our unique environment, built with the toughness needed to withstand the rigors of public life and features that ensure minimal cleaning time and maintenance costs.

As market leaders, we understand the demands placed upon community infrastructure and furniture, and have engineered and built our barbecues accordingly – vandal resistant, easy to install, easy to clean and top cooking performance time-and-time again.

When building family-friendly outdoor, public gathering places, Furphy Barbecues meet and exceed all functional and logistical expectations.

Made in Australia by Australians, with a range of optional features, our barbecues can be adapted to suit any location - from salt-aired coastal landscapes to the wide open spaces of regional Australia. Opt for ready-made, or we can custom build to suit the individual needs of your region or chosen public space.

Protected by a near unbreakable exterior, is our industry-leading heating technology that delivers a fantastic cooking experience time-after-time, all backed by a structural and electrical warranty, and unmatched after sales service Australia-wide.



*When building family-friendly outdoor, public gathering places, Furphy Barbecues meet and exceed all functional and logistical expectations.*



**TOUGH  
& DURABLE**



**EASY CLEANING  
& MAINTENANCE**



**COOKING  
PERFORMANCE**



**WARRANTY & AFTER  
SALES SERVICE**



## TOUGH & DURABLE

To meet the challenges of regular use in the great outdoors, Furphy Barbecues are made with the highest regard to detail and with fit-for-purpose toughness.

The **Evolve** model is built with a marine grade stainless steel bench top, supported by a thick robust aluminium frame, encased in colour coated steel sheeting and panels, with heavy duty marine ply.

The **Access** and **Premium** models take durability a step higher, designed and manufactured with stainless steel throughout.

You can be confident that the one-piece pressed stainless steel hot plate on all models (and available for custom facilities or retrofits) provides strength, hygiene, longevity and performance.



## COOKING PERFORMANCE

The hallmark of the patented Intuitive Cooking Control used in Furphy Barbecues is simplicity of use for maximum performance. The single button, one press button initializes the auto-sterilization of the cook top, as the heat increases to 230°C in quick smart time. Auto shut-off after 30 minutes (with an option of one-press shut-off) ensures energy efficiency.

Where crowds gather, and the amount of food needed to be cooked increases, consistency of heat across the plate becomes critical. Users want to cook steaks, not stew them! Furphy's patented Intuitive Cooking Control, using digital technology, monitors plate temperature more quickly than commonly used mechanical thermostats, and adjusts accordingly, giving a more consistent temperature across the plate all the way to the edges. Thanks to combining this technology and a 444-grade stainless steel hot plate – no more lukewarm cooking.

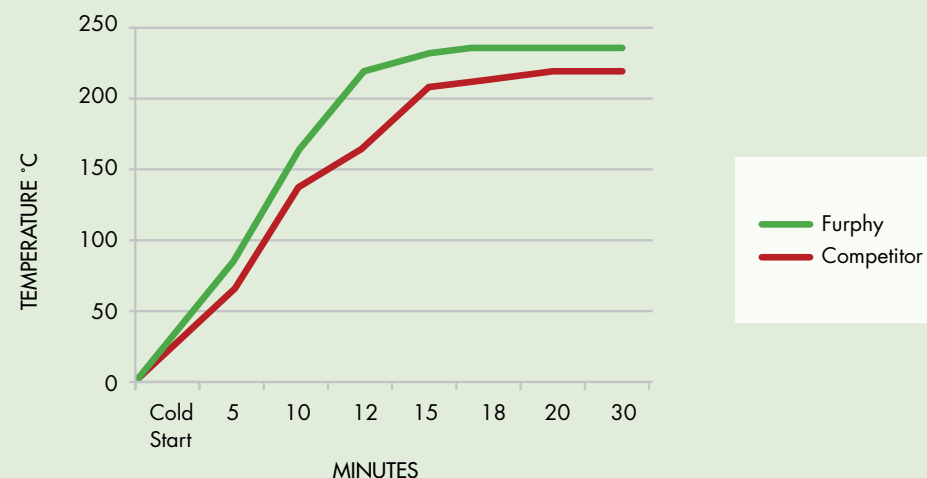

The Intuitive Cooking Control as tested by independent authority accredited by NATA (National Association of Testing Authorities Australia) has among the fastest heat-up times and temperature consistency on the market.

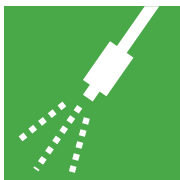

## EASY CLEANING & MAINTENANCE

With many public barbecues being cleaned hundreds of times per year, minutes saved during each clean quickly add-up and represent significant savings. Furphy Barbecues are designed with innovative features that ensure quick-and-easy cleaning.

With no exterior entrapment points, ventilation holes or buttons around the hot plate, high pressure water cleaning can be used with minimal fuss and without fear of damaging internal electronics.\*

The frame of the barbecue is designed to ensure no entrapment ledges or points where water, grease or other debris can lodge. No build up means less chance of bacteria and less need for cleaning.

The industry-leading heating up times of the Furphy hotplates also quickens cleaning time for cleaners who rely on heating to clean the plate. The unique “waste bag” provides the fastest and most cost-effective method of removing residual cooking waste on the market.

The days of cleaners scraping out internal waste are over. Cleaners can now save significant time and cost by simply removing the heat resistant waste bags, ensuring they can clean more barbecues per hour, particularly in peak periods. It's as easy as ABCD:

- A] Open front door
- B] Slide out waste bag receptacle
- C] Dispose of heat resistant waste bag
- D] Replace with new heat resistant waste bag.\*\*

\*Internals are protected within an ip65-rated enclosure.

\*\*Each unit comes with 50 bags, and replacement bags can be provided quickly.



## WARRANTY & AFTER SALES SERVICE

All Furphy barbecues come with a five year structural and two year electrical warranty, backed by nation-wide servicing and parts supply.

Furphy's smart plug-and-play electronics ensure that in the event of malfunction, the barbecues can quickly be repaired and less mechanical parts mean greater reliability.



# EVOLVE BARBECUES



The barbecue of choice where colour and design options are the priority.

- The Furphy Intuitive Cooking System.
- Furphy's unique BBQ waste bag collection assembly.
- Aluminum and stainless steel construction.
- Option of delivered fully assembled or flat-packed, ready-to-assemble.
- Choose from a range of panel colours.
- Choose from different configurations of hotplates and/or sink.
- Class-leading heat-up times.
- Cost effective cleaning and maintenance features.

## Panel Colours

All doors and frames come in Aztec Silver as standard.



Aztec Silver



Pale Eucalypt



Wind Spray



Ironstone



Paperbark



Surfmist

\*Custom colours and finish options for panels available on request.

## Configuration Options

KB401 – Single

KB402 – Double with two plates

KB403 – Double with 1 plate and 1 sink



## EVOLVE // SINGLE

Side view:

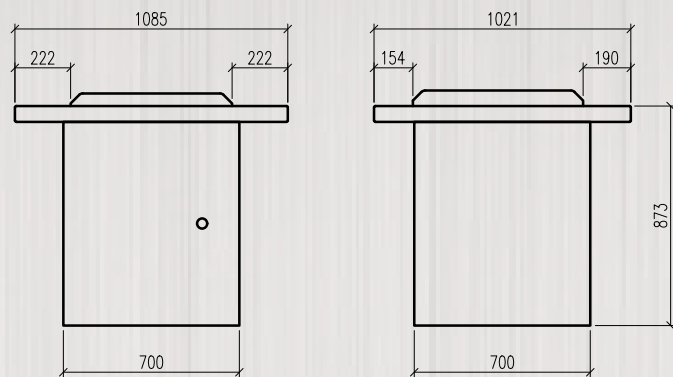

Top view:

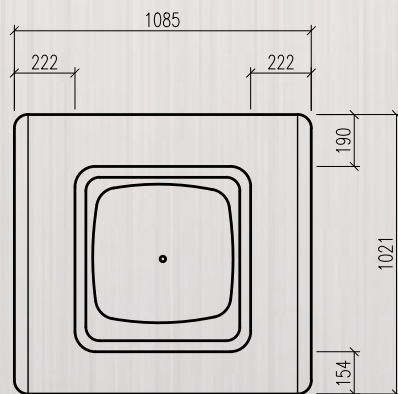

## EVOLVE // DOUBLE

Side view:

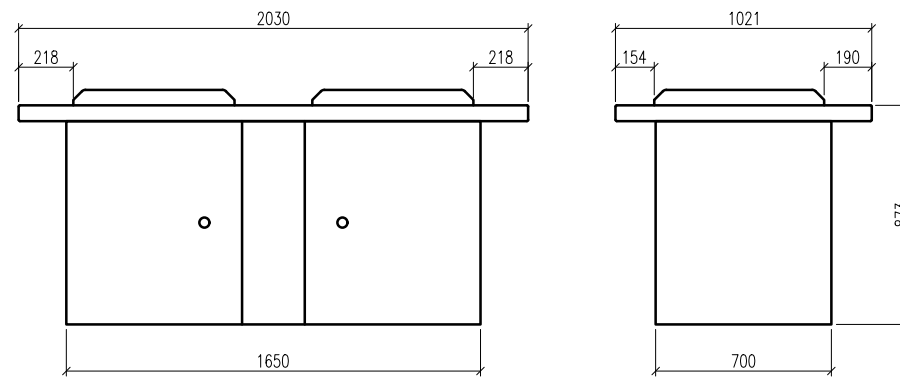

Top view:

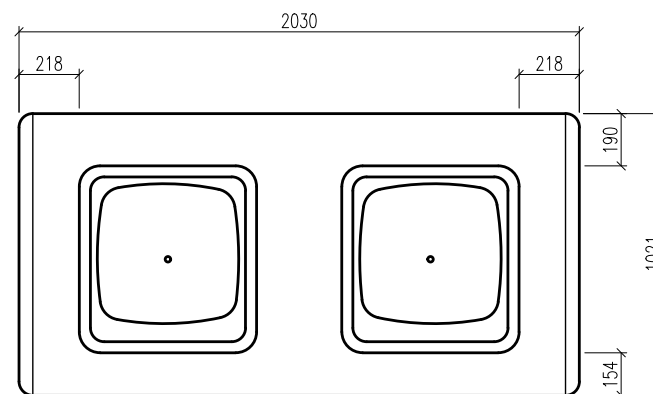



## PREMIUM BARBECUES



This is the barbecue of choice for harsher, corrosive environments, where toughness is the priority.

- The Furphy Intuitive Cooking System.
- Furphy's unique BBQ waste bag collection assembly.
- Robust stainless steel construction with fully welded seams.
- Delivered fully assembled and ready for use.
- Stainless steel construction throughout.
- Ideal for high corrosive areas.
- Class-leading heat-up times.
- Low maintenance features.

### Configuration Options

KB401 – Single

KB402 – Double with two plates

KB403 – Double with 1 plate and 1 sink

.....

*Protected by a near unbreakable exterior, our industry-leading heating technology delivers a fantastic cooking experience time-after-time.*

.....

## PREMIUM // SINGLE

Side view:

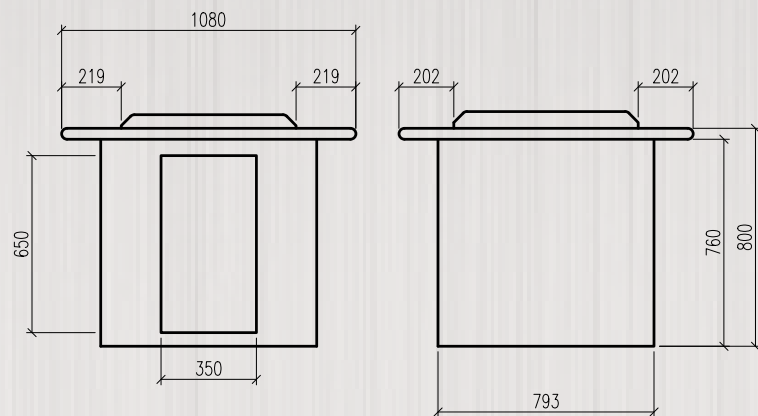

Top view:

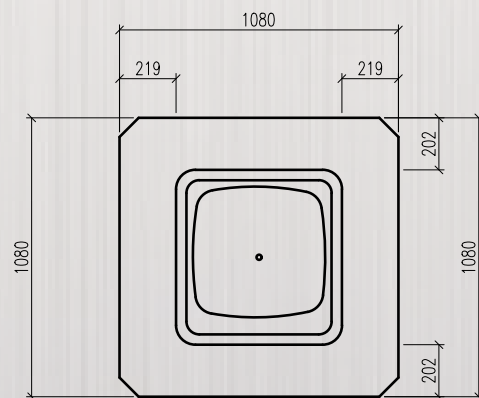

## PREMIUM // DOUBLE

Side view:

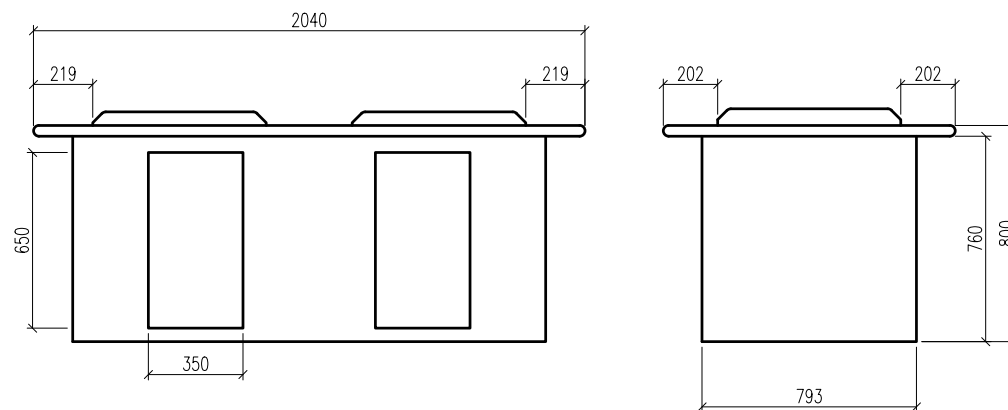

Top view:

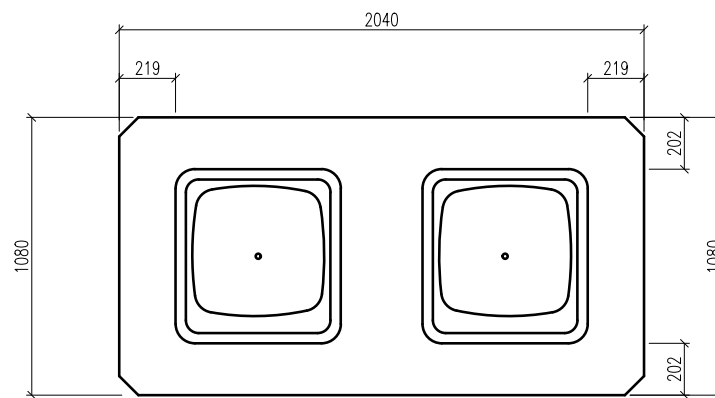



# ACCESS BARBECUES



The barbecue giving full accessibility to people in wheelchairs.

- The Furphy Intuitive Cooking System.
- Furphy's unique BBQ waste bag collection assembly.
- All features of the Premium Barbecue.
- Recessed cabinet allowing wheelchair access.
- Designed using AS1428 principles for access and mobility.
- Collaborated with Access Consultant for design and usability.
- Stainless steel construction throughout.
- Delivered fully assembled and ready-for use.



## Configuration Options

KB501 – Single

KB502 – Double with two plates

KB503 – Double with 1 plate and 1 sink

## ACCESS // SINGLE

Side view:

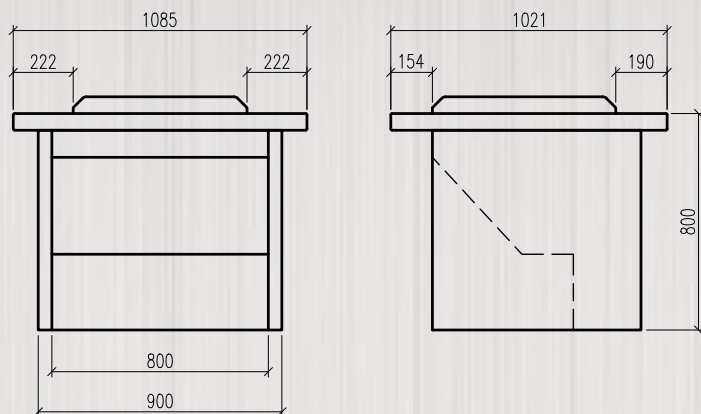

Top view:

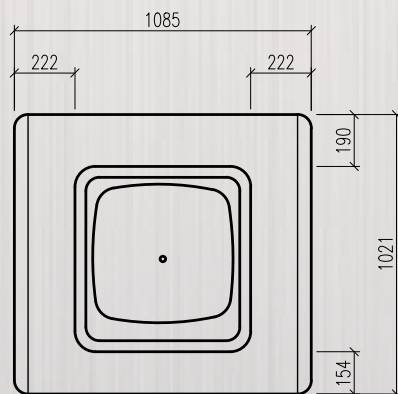

## ACCESS // DOUBLE

Side view:

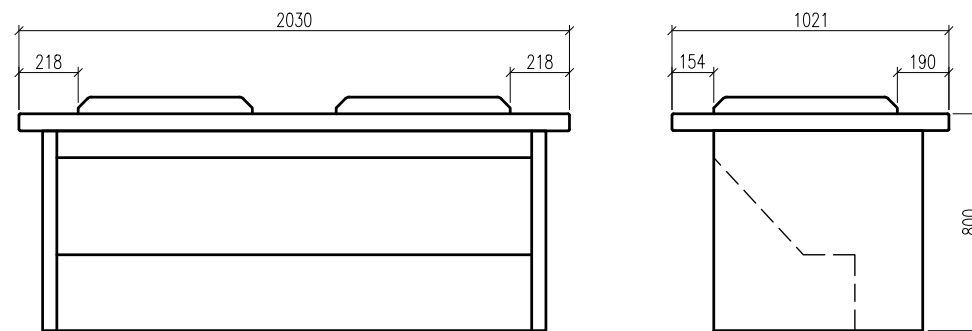

Top view:

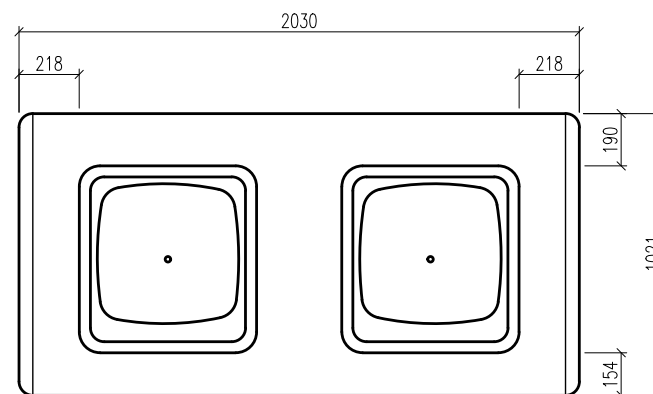

# CUSTOM BBQ OPTIONS

Any space and any environment can enjoy the quality cooking, low maintenance and easy cleaning features of the Furphy's Intuitive Cooking System.

If you have individual design requirements, you can opt for the Furphy drop-in hot plate (the same plate mounted within the **Evolve**, **Access** and **Premium** Barbecues) in concert with your individual designs or retrofit into an existing barbecue.

Whether your custom barbecue construction preference is brick, timber or metal, ask Furphy about the design of your entire suite, or Furphy can simply supply and/or install our hot plate (made from 444 grade stainless steel) and cooking system.

Furphy can supply any custom solution for any unique requirement.

.....  
*When building family-friendly outdoor, public gathering places, Furphy Barbecues meet and exceed all functional and logistical expectations.*  
 .....

## DROP-IN OPTION

All the benefits of the Furphy hotplate, and its Intuitive Cooking System are available by retrofitting existing barbecues. [Option KB701]



Front view:

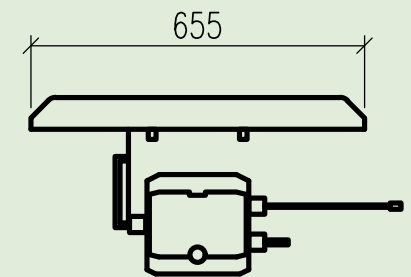

Top view:

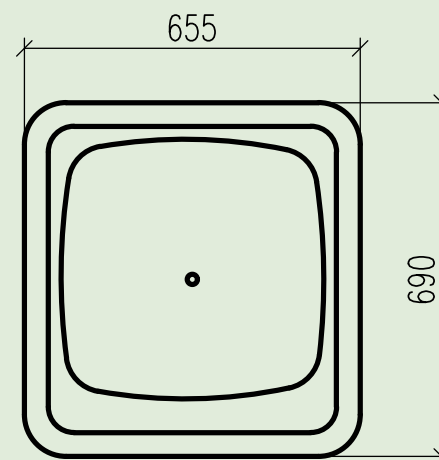

Side view:

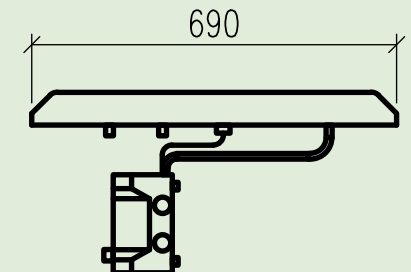



## INSTALLATION

On request, Furphy Foundry can install your BBQ facilities in all states of Australia.

NOTE: All Furphy Barbecues must be installed on a concrete slab at least 450 mm larger than the bench top on all sides.

Furphy recommends considering access principles when planning the installation of KB501, KB502 and KB503 models.

.....  
*Built with the toughness needed to withstand the rigors of public life and features that ensure minimal cleaning time and maintenance costs.*  
.....

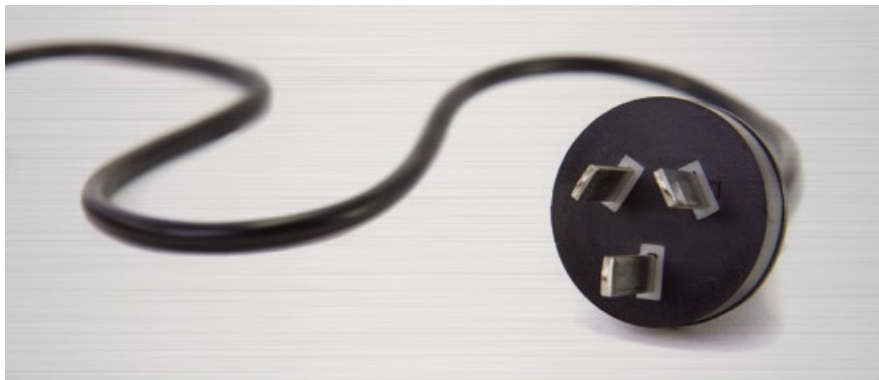

## POWER REQUIREMENTS

Furphy Barbecues can be powered directly from the mains power (10 amp, 240 volt).



Sold exclusively through Landmark Products and RWA (South Australia) with offices throughout Australia and New Zealand. For more information, contact your local Project Consultant.

PHONE // **1300 768 230**

EMAIL // **bbq@furphyfoundry.com.au**

WEB // **www.furphyfoundry.com.au**



[www.furphyfoundry.com.au](http://www.furphyfoundry.com.au)