

SAFETYLINE JALOUSIE



THE FUTURE LOUVRE

DESIGN MANUAL

CONTENTS

About Safetyline Jalousie	04	Automation	42
		Automation, Smoke Relief	43
Product Information	06	TJX3701 Internal Drive Features	44
		SLJ01 EXT Drive Features	45
Technical Information	08	Installation	46
Frame with Glass Louvres	08		
Frame with Aluminium Louvres	09	Various Fixing Examples	47
Frame with Combination of Louvres	10	Timber Reveal	47
Frame with Fly Screen	11	Brick Veneer	48
Frame with Transoms & Fly Screen	12	Stud Cladding	49
Frame with Vacuum Glass Louvres	13	Blockwork - Sill Block/ Flat Sill	50
List of Profiles	14	Brick Double - Flat/ Sill	52
		Integration with Aluminium Sub-Frame	54
Features	16	Timber Frame	55
		Sub-Head and Sub-Sill Installation	56
Performance	18	Guarantee	58
Australian Standards and Key Performance Ratings	18		
Serviceability Wind Pressures (SLS)	18	Maintenance	59
Ultimate Limit State (ULS)	19		
Air Infiltration	19	Contact Information	60
Water Penetration Resistance Acoustic Performance	19		
Windborne Debris, Impact Loading	21		
Window Energy Rating Scheme (WERS), U-Value & SHGC Calculation	21		
Air Infiltration, Energy Modeling	22		
Louvre Performance Analysis	23		
Specifications	26		
JX Louvre Window with Vacuum Glazing	26		
Bushfire Specifications	28		
Comprehensive Specification	29		
Standard Heights – Glass Louvres	30		
Standard Heights – Vacuum Glass & Aluminium Louvres	31		
Intermediate Transom Detail	33		
Standard Lever and Motor Operations	34		
Choice of Handles	38		
Frame Joint	40		
Reinforcer for use as Balustrade	41		



Safetyline Jalousie goes beyond all other louvre systems



**Performance Louvre Windows
Design Manual Version 3**

SMR Design Pty Ltd
ABN 23 123 507 853

Unit 3/11-17 Wilmette Place,
Mona Vale NSW 2103

sales@safetylinejalousie.com.au
safetylinejalousie.com.au

ABOUT SAFETYLINE JALOUSIE

Available in Australia

SMR Designs Pty Ltd, a member of the Australian Glass and Window Association, has been authorised to manufacture and distribute Safetyline Jalousie louvre windows in Australia and the South Pacific.

The family owned and run business has had more than 30 years involvement in the Australian home improvement and commercial premises building market with its revolutionary Vergola Opening Roof System. It introduced Safetyline Jalousie louvres to the Australian windows and doors market in 2009.

The Safetyline Jalousie product is the perfect ventilation option overcoming the safety and security limitations of conventional louvre windows and is aligned with the company's commitment to quality, value and superior design.

Created in France, Safetyline Jalousie louvre windows have been developed exclusively by Technal, a division of the European giant Hydro. Hydro is a world leader in the aluminium building systems sector with activities in more than 40 countries on all continents.

Along with Technal's extensive range of windows, doors, facades, balustrades and partitions, Safetyline Jalousie louvre windows have a long history of superior performance in commercial and residential buildings across the globe.

ABOUT



Customer Assistance

SMR Designs Pty Ltd, with its Safetyline Jalousie product, offers architects, window companies and building partners:

- Complete design and fabrication documentation;
- Complete CAD* drawings in DWG and DXF format; 3D files for Autodesk® Revit® Architecture and ArchiCAD 3D Architecture Software are also available.
- Technical assessments and quotations;
- Adaptation of custom designed profiles; and
- Installation and maintenance training.

* Each CAD drawing in this manual has a JX code which corresponds to the DWG or DXF file contained in the resource disc and online at www.safetylinejalousie.com.au

A Revolution in Louvre Windows

Safetyline Jalousie goes beyond all other louvre systems to provide:

- Extra wide spans, up to 1400mm;
- Inbuilt security;
- Air and water tight sealing and;
- Internal fly screens.

With aluminium frames and support structures, the louvres may be manufactured from aluminium or glass, which provides a natural and soft ambience.





PRODUCT INFORMATION

Advantages & Benefits

Safetyline Jalousie's unique louvre windows will bring value to your projects and offer unrivalled flexibility in your design options through unmatched performance ratings, strength, reliability and versatility.

Some of the performance advantages and benefits of Safetyline Jalousie louvre windows include:

- Span of 1400mm wide, larger windows reduce perimeter framing and install time, which is hugely cost effective;
- Seals are air and water tight, with a Water Penetration Resistance of 800pa. Ideal for air-conditioned environments and strong wind load requirements such as high rise buildings;
- Acoustic benefits are some of the highest ratings available. Tested and confirmed sound reduction of 33Rw achieved with 6.38mm laminate and 6mm toughened glass and sound reduction of 35Rw achieved with Viridian 6.5mm Laminate Hush glass;
- Security is provided via the louvre bearer with a pull out force in excess of 200 kgs – Safetyline Jalousie louvres can be left open with complete peace of mind;
- Meets balustrade and fall prevention requirements, perfect for floor-to-ceiling, multi-story, high-rise and balcony enclosures and winter gardens;
- Screening is provided internally and is easily removed for cleaning, eliminating the use of a permanent boxed out section, allowing greater cross flow ventilation, free flow air infiltration and natural light.

Safetyline Jalousie louvre windows are amongst the safest, strongest, widest, most functional and versatile louvre windows on the market. The lifestyle and energy saving benefits are considerable and in an era of sustainable design, the JX from Safetyline Jalousie is the clear winner.

Frame with Glass Louvres

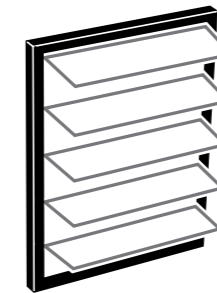

Frame with Aluminium Louvres

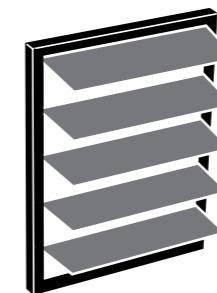

Frame with Combination of Louvres

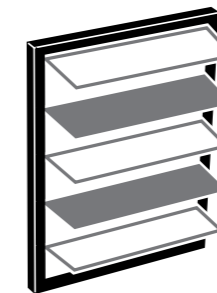

Frame with Fly Screen

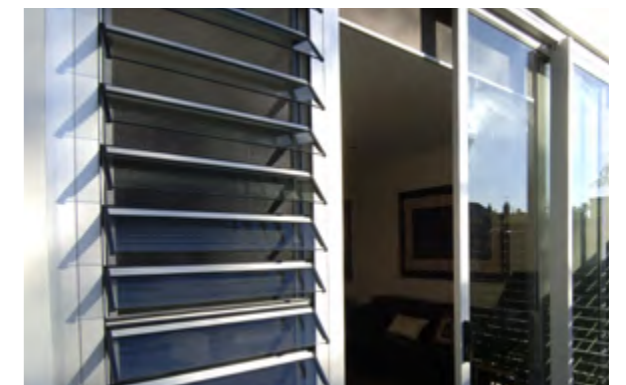
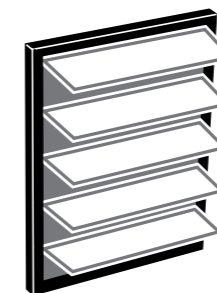



Frame with Glass Louvres

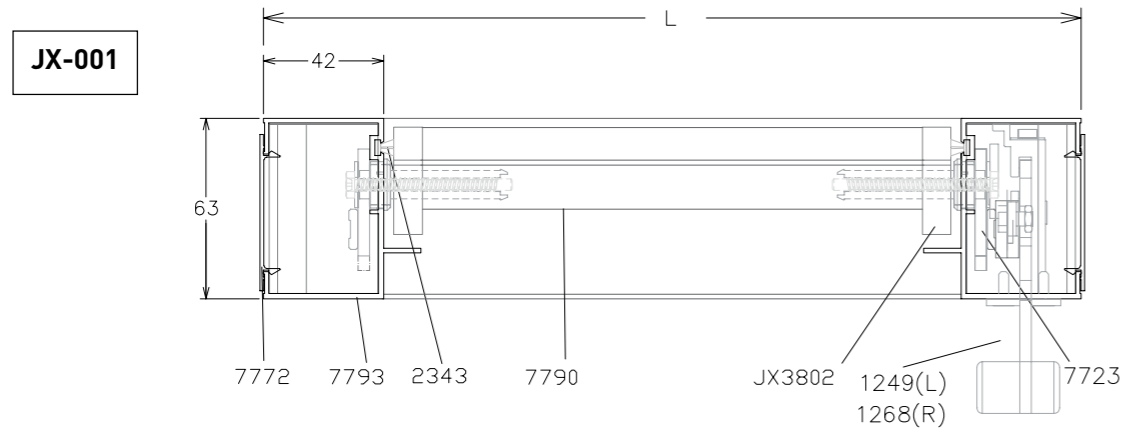

Frame with Aluminium Louvres

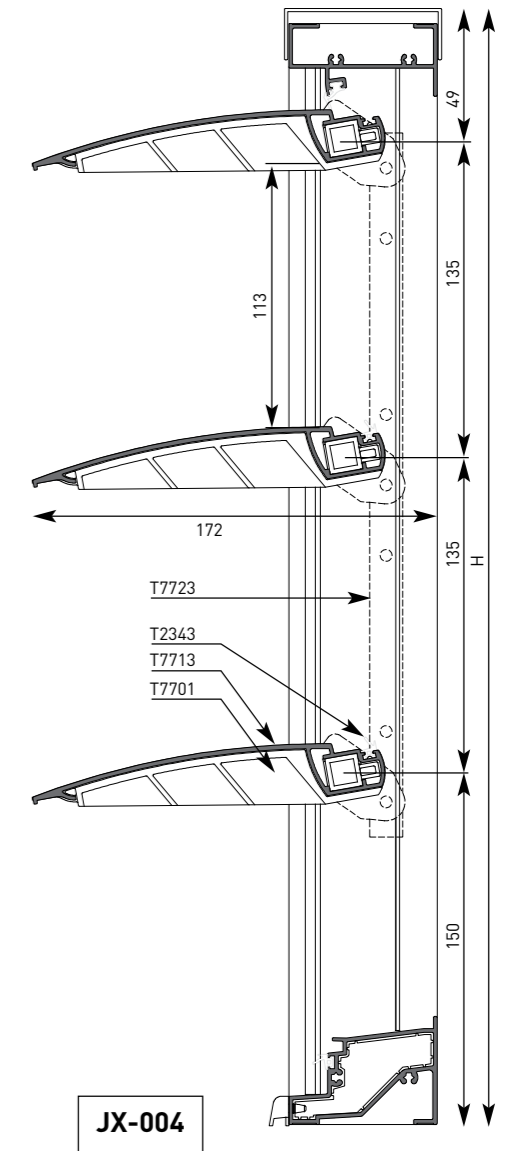
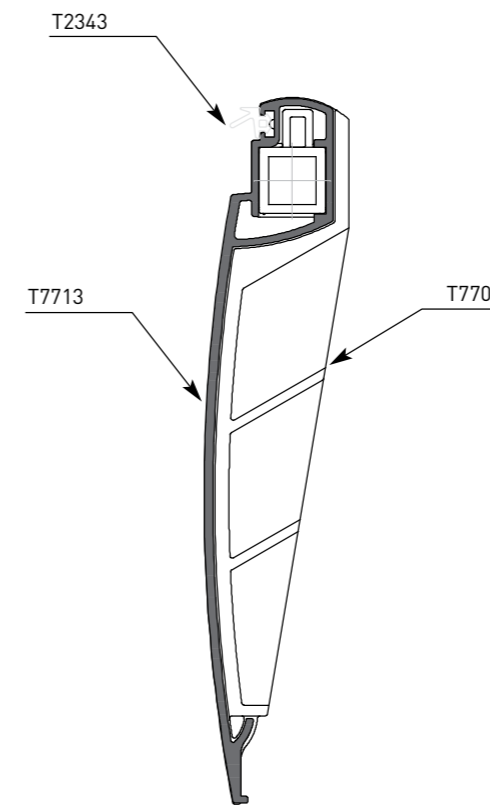
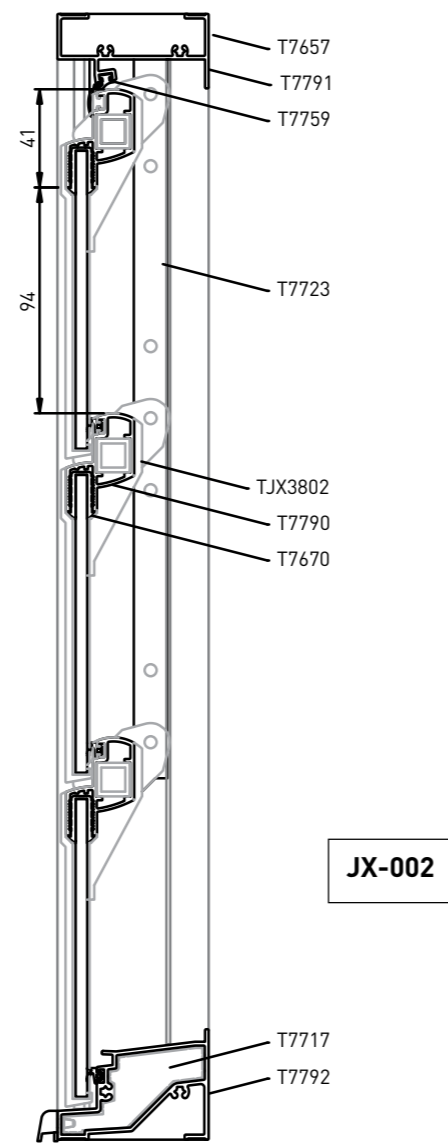
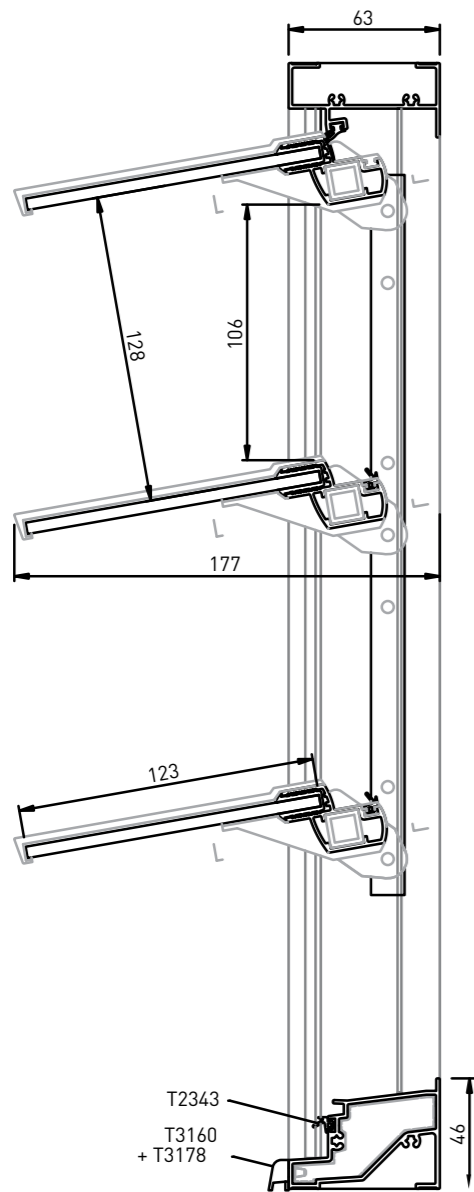
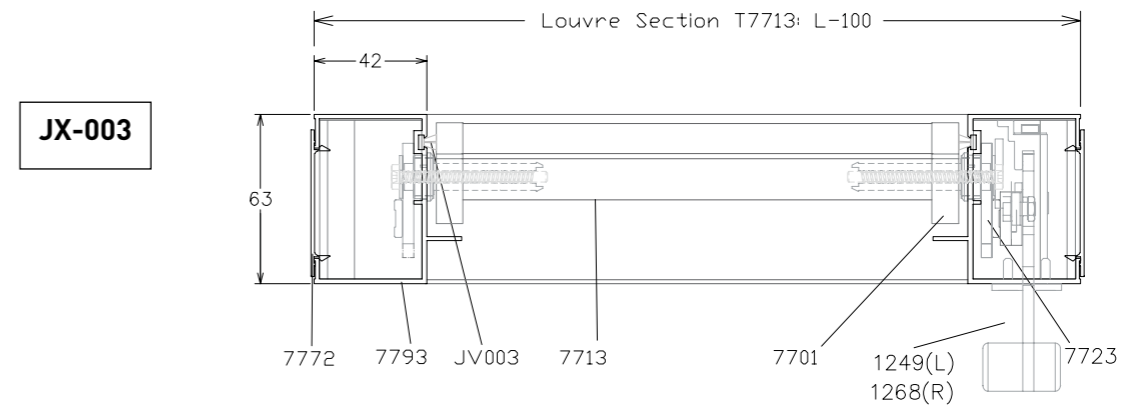



Frame with Combination of Louvres

(glass and aluminium louvres)

JX-001

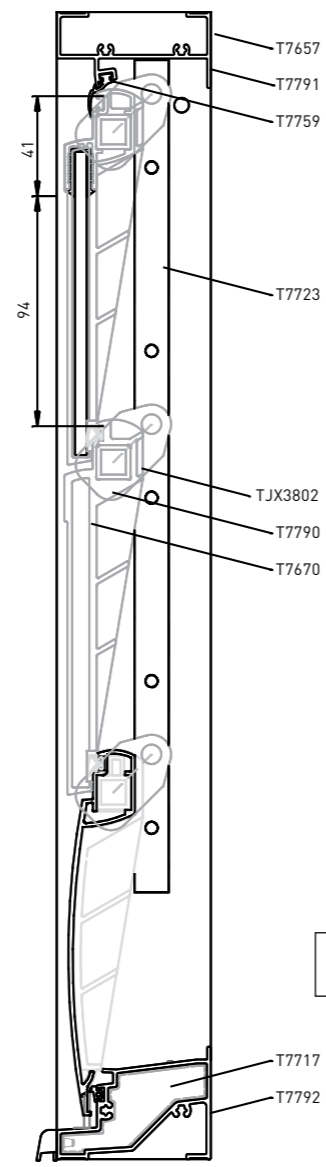
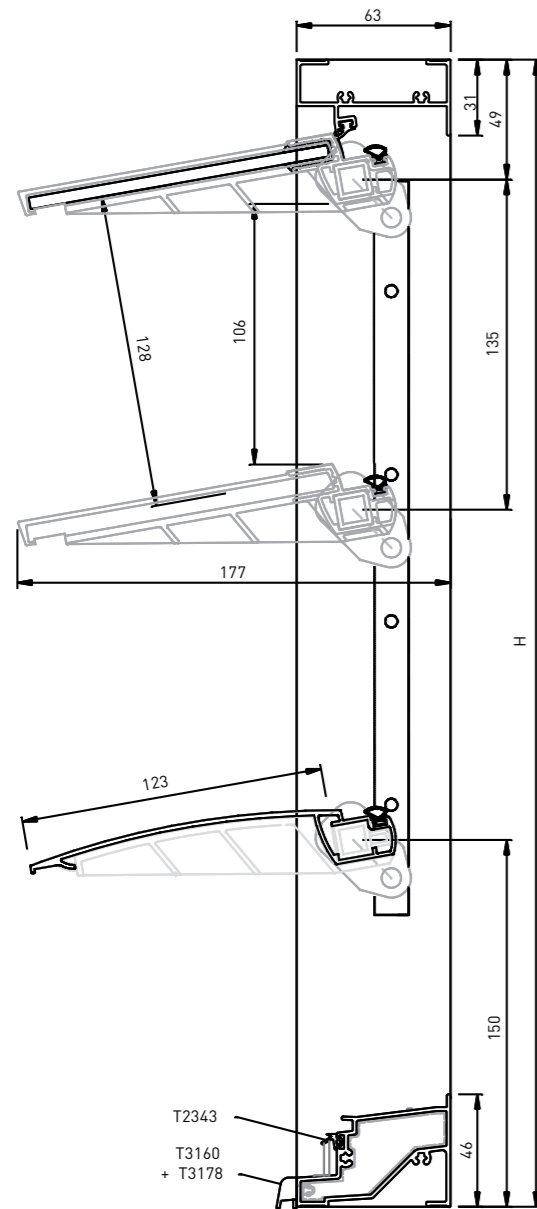
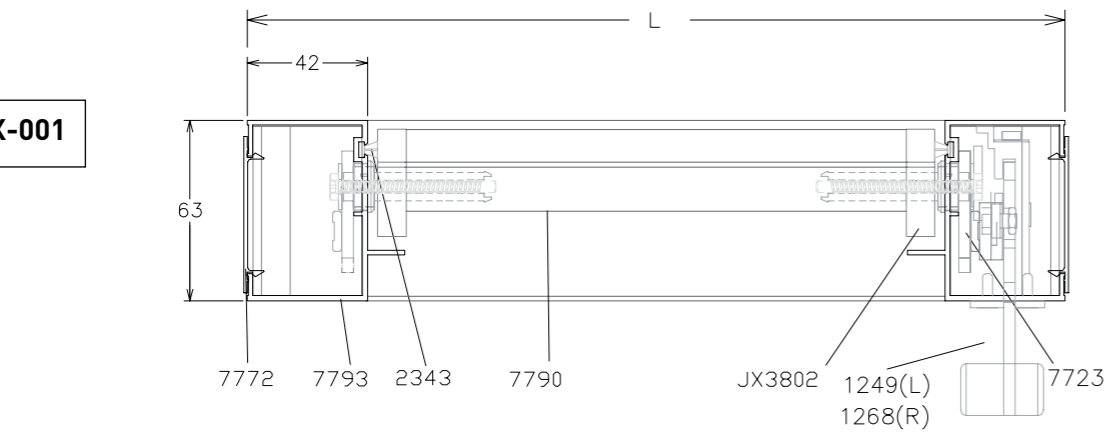

JX-005

Frame with Fly Screen

JX-006

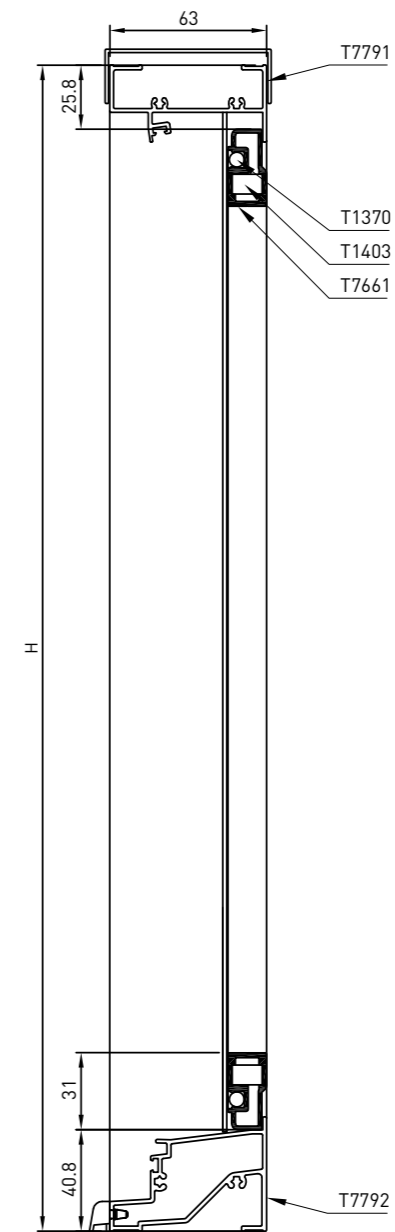
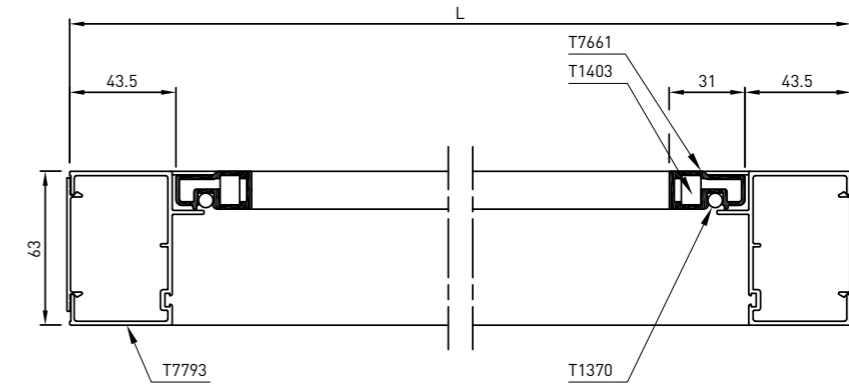

JX-007



Frame with Transoms and Fly Screens

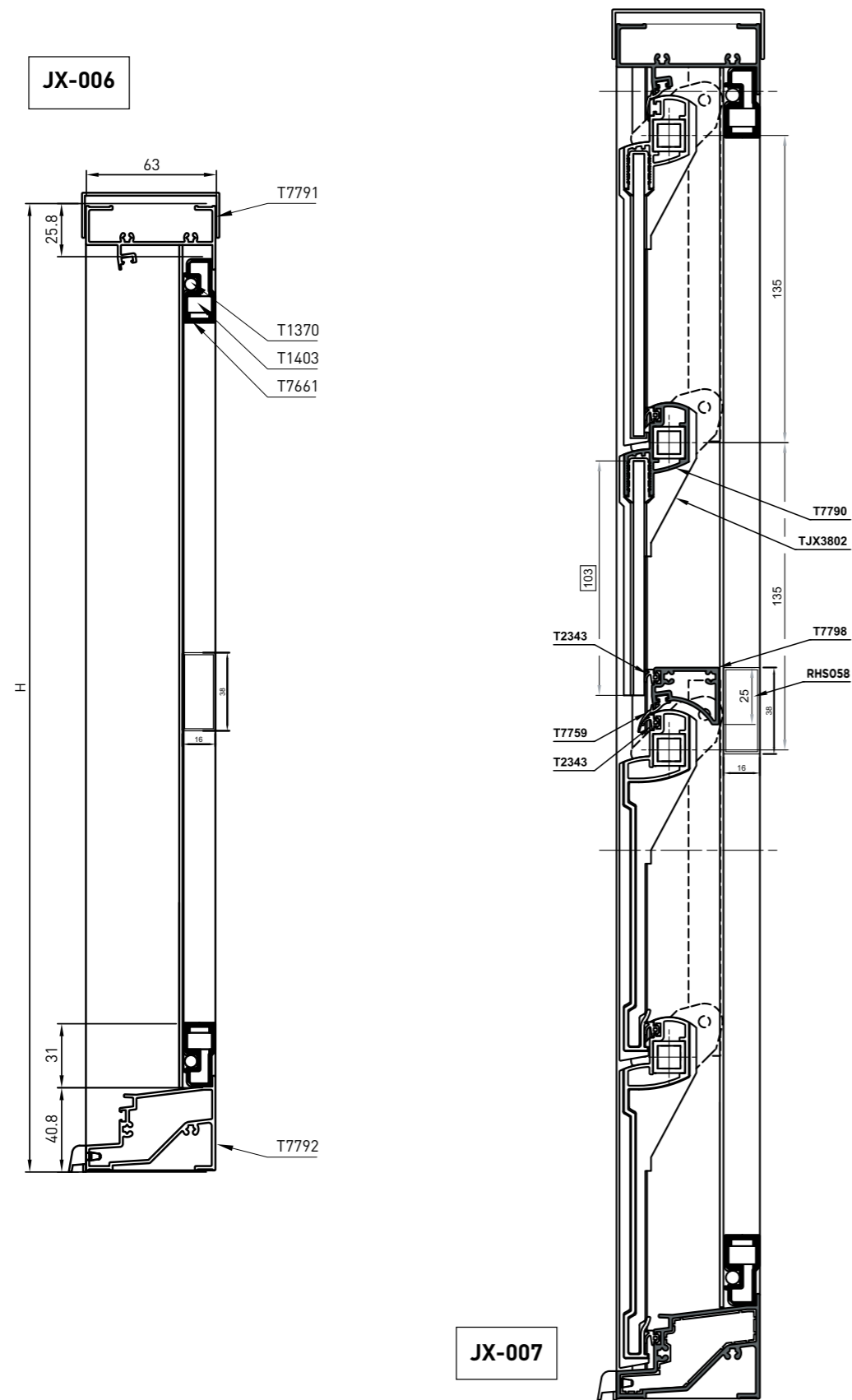

Frame with Vacuum Glass Louvres

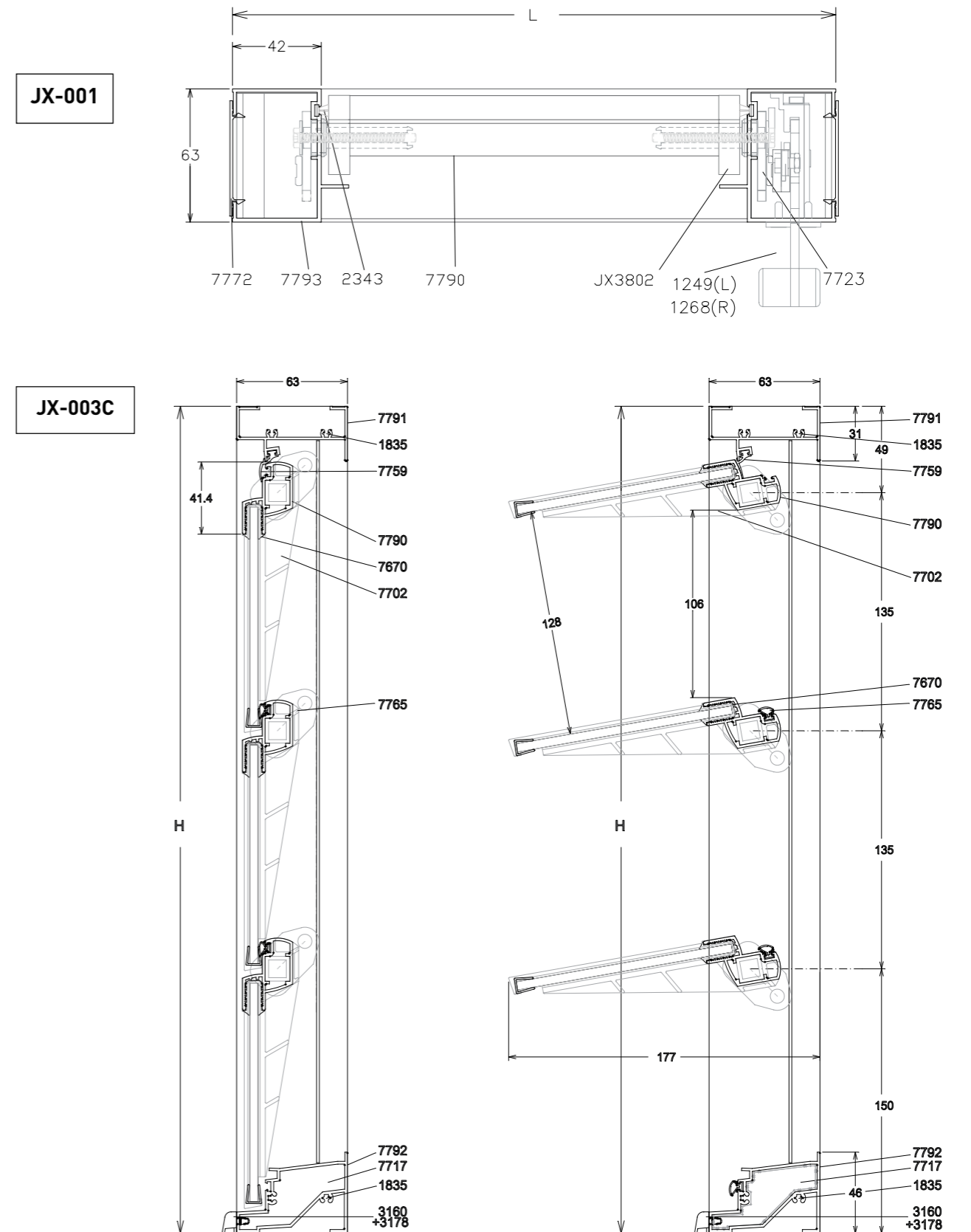



List of Profiles

Top Transom

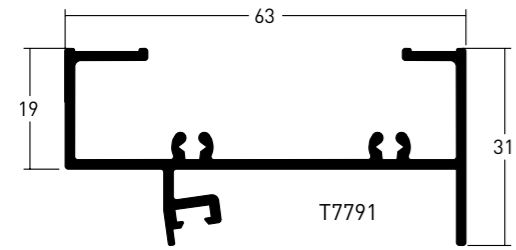

Fly Screen Section

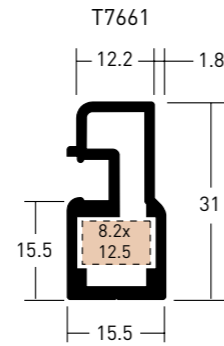

Bottom Transom

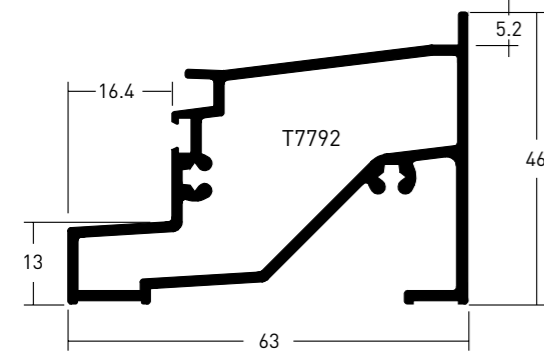

Intermediate Transom

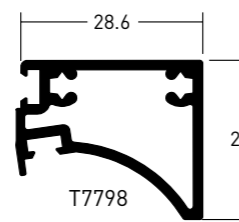

Sub Head

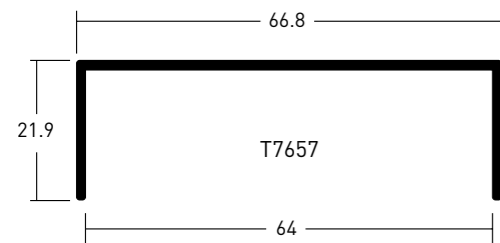

Sub Sill

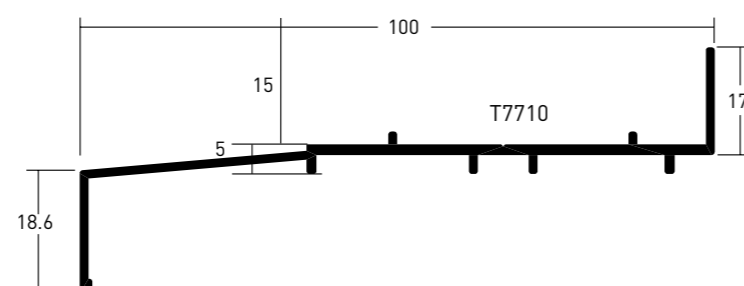

List of Profiles

Upright Section

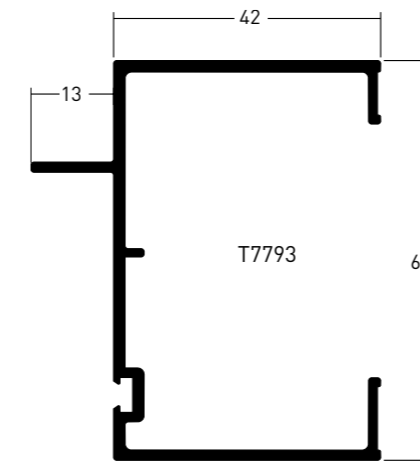

Glass Louvre Bearer

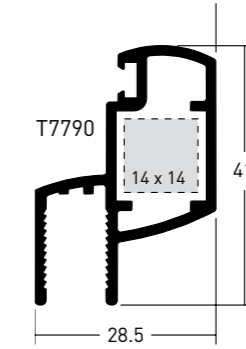

Stainless Steel Security Rod

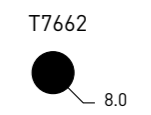

Joining Section



Capping Section

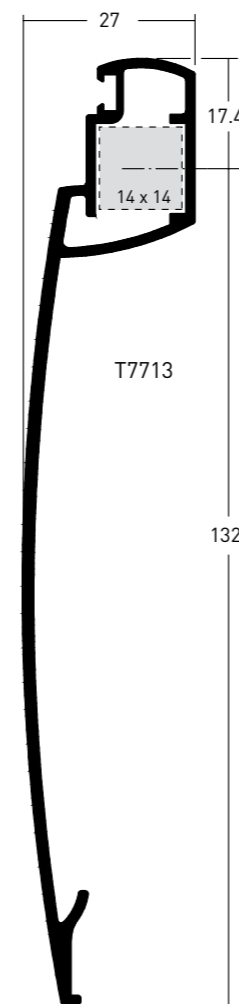
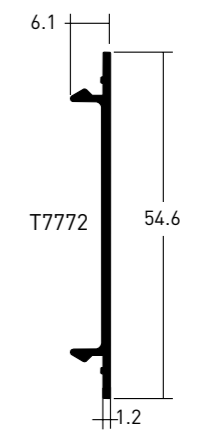

Sub-Frame Mullion Section

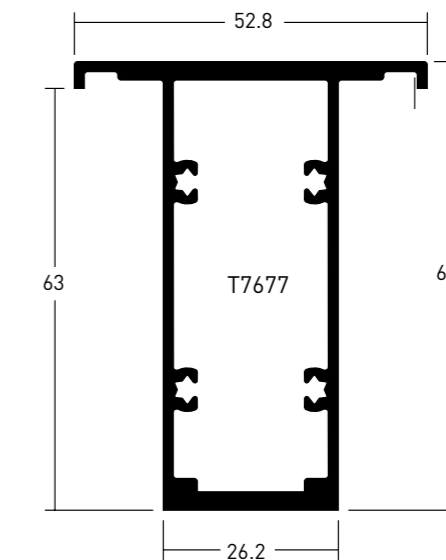



FEATURES

Spans

- Extra wide spans up to 1400mm as a single unit or frames can be joined with a connector piece.

Security

- Inbuilt & impenetrable;
- Robust aluminium louvre bearers are built into the frame – even if the glass is broken the system remains secure;
- 8mm internal security bar option available – The rod is fitted inside the louvre bearer which does not affect the appearance of the system.

Seals

- Sealed on all 4 sides with Marine Grade EPDM seals on each horizontal transom and gaskets on the upright sections;
- Water drainage via bottom transom.

Screens

- Insect screens are fitted internally within a rebate section of the window frame, and are easily removed for cleaning;
- Available in fibreglass or aluminium mesh.

Frames

- Extremely durable, high quality 63mm module square cut aluminium frame assembled by stainless steel screws;
- The aluminium components are available in three surface finishes – powder coated, high performance powder coated or anodized;
- A wide range of colours are available to meet individual project requirements, enhancing existing buildings and offering architects and designers greater design freedom;
- Anodising thickness is 20 microns or 25 microns for seaside and inland locations where durability and longevity are of importance;
- Super durable DecoWood finish can be applied to the aluminium where the look of timber is desired.

Louvres

- Louvres are available in glass or curved aluminium profile with nylon end caps;
- Any type of commercially available glass can be used in 6mm, 6.38mm or 6.5mm thickness – including laminate, low e, tinted, frosted, acoustic and performance glass;
- Aluminium louvre blades are one piece and cannot be removed;
- Combination of glass and aluminium louvres are possible;
- Louvre blade centres are 135mm;
- Requires 200kg pull out to remove glass louvre blades;
- Louvres open to the outside of the window – no interference to curtains or blinds.

Installation

- No assembly required – The system is supplied fully manufactured and glazed;
- Easy and fast installation using screws through the pre-punched fixing holes in the upright sections.

Operation

- Manual operator options include a cam driven lever mechanism or turn handles which open the louvres to 80° and can be fitted on the left or right hand side of the frame;
- High level louvres can be operated with a winding mechanism and detachable map rod;
- Louvres can be motor controlled using a 12V DC or 24V DC Actuator with wall switch and/or hand held remote;
- Motorised louvres can be integrated with climate control, fire and smoke systems;
- Internal and external motor options available.





PERFORMANCE

Australian Standards

Safetyline Jalousie Louvres exceed the mandatory requirements of Australian Standards AS2047-2014 (Windows and Glazed Doors in Buildings), AS1288-2006 (Glass in Buildings – Selection and Installation) and AS4055-2012 (Wind Loads for Housing).

All windows are labelled with their identification, window rating and water penetration resistance.



Key Performance Ratings

- Ultimate Limit State (ULS) – up to **9525pa**
- Serviceability Limit State (SLS) – up to **4000pa**
- Water Penetration Resistance – **800pa**
- Air Infiltration – **tested to 0.12L/Sqm/S**
- Acoustic – **35RW**
- Impact Load – tested to **550kg**
- Meets balustrade requirements
- Meets Fall prevention requirements
- Windborne Debris – impact test passed **type B** (for cyclones)

Serviceability Wind Pressures (SLS)

The following graph has been developed using actual test data and calculations to confirm compliance.

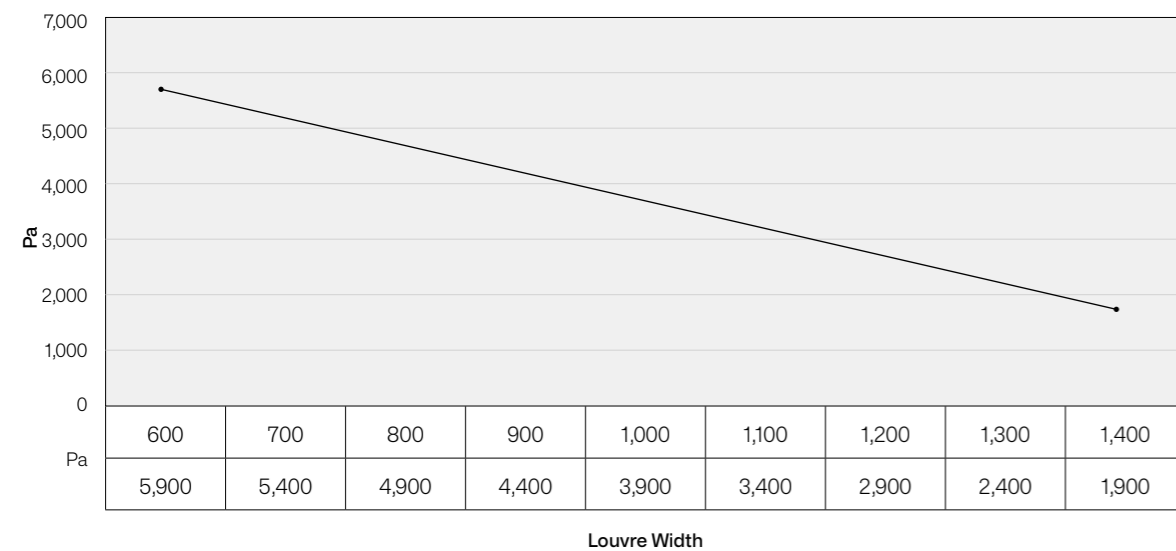

The following tables list actual test results for the JX Safetyline Jalousie louvres conducted by a NATA accredited test laboratory.

Ultimate Limit State (ULS)

Product Type	Test Report Number	Ultimate Wind Pressure Pa		Window Height Tested (mm)	Window Width Tested (mm)
		Positive	Negative		
Glass Louvres	AZT0518.18	8,700	8,000	1,684	1,400
Glass Louvres	AZT0519.18	9,000	8,000	2,629	1,000
Glass Louvres	AZT0517.18	7,000	7,000	2,629	1,400
Aluminium Louvres	AZT0013.12	8,900	7,600		1,000
Aluminium Louvres	AZT0010.12	9,100	7,900		1,400

Air Infiltration

Product Type	Test Report Number	Air Infiltration L/s m ²	Window Height Tested (mm)	Window Width Tested (mm)
		75 Pa		
Glass Louvres	AZT0254.19	0.12Ls ⁻¹ m ⁻²	2,629	1,400
Aluminium Louvres	AZT0010.12	0.16Ls ⁻¹ m ⁻²		1,400

Water Penetration Resistance

Product Type	Test Report Number	Water Penetration Resistance (pa)	Window Height Tested (mm)	Window Width Tested (mm)
Glass Louvres	AZT0518.18	800	1,684	1,400
Glass Louvres	AZT0519.18	800	2,629	1,000
Glass Louvres	AZT0254.19	600	2,629	1,400
Aluminium Louvres	AZT0016.12	700		600
Aluminium Louvres	AZT0010.12	600		1,400

Acoustic Performance

The following Rw ratings were achieved with the Safetyline Jalousie system in an accredited CSIRO test laboratory;

Safetyline Jalousie JX Louvre Windows have been designed with acoustic performance in mind and, with the right glass selection, sound reduction of up to Rw 35 is achievable.

**Rw 33**

6mm toughened monolithic glass

Frequency	125	250	500	1000	2000	400
Single Octave Rw	25.1	28.6	31.1	34.7	32.1	29.0

Frequency (Hz)	100	125	160	200	250	315	400	500	630	800	1000	1250	1600	2000	2500	3150	4000	5000
1/3 Octave Rw	24.7	25.2	25.4	27.9	27.9	30.4	29.8	31.3	32.4	33.8	34.9	35.5	34.4	31.7	30.9	30.2	29.6	27.7

Rw 33

6.38 laminated glass

Frequency (Hz)	125	250	500	1000	2000	400
Single Octave Rw	24.7	28.3	31.0	34.7	32.9	30.0

Frequency (Hz)	100	125	160	200	250	315	400	500	630	800	1000	1250	1600	2000	2500	3150	4000	5000
1/3 Octave Rw	24.6	25.0	24.6	27.6	27.7	30.2	29.7	31.2	32.6	33.7	35.0	35.6	34.9	32.4	31.8	32.4	30.2	28.3

Rw 35

6.5mm Laminate Hush

Frequency (Hz)	125	250	500	1000	2000	400
Single Octave Rw	25.2	28.6	31.3	35.2	36.9	30.2

Frequency (Hz)	100	125	160	200	250	315	400	500	630	800	1000	1250	1600	2000	2500	3150	4000	5000
1/3 Octave Rw	24.3	25.8	25.6	27.6	28.1	30.7	30.1	31.4	32.9	34.0	35.3	36.4	37.2	36.9	36.5	33.6	30.2	28.2

**Windborne Debris Impact Loading – Type B Compliant**

Australian Standard AS/NZ1170.2 clause 2.5.7 specifies requirements for windborne debris impact loading criteria. Safetyline Jalousie glass blade louvres were tested for Debris Type B (8mm steel ball missile). Debris Type B in the Australian Standard calls for an 8mm steel ball. We fired 5 x 8mm steel balls to conform to the higher requirements of cyclone shelters in North Queensland (all test were done with 5 balls). We achieved the following results: Debris Type B Pass at 45 meters per second (highest Australian Standard) and exceeded standard and pass at 60 meters per second with 5 x 8mm steel balls.

Fall Prevention Requirements

The National Construction Code specifies various requirements for the prevention of falls from openable windows. The intent of these requirements is to limit the risk of a person (especially a young child) falling through an openable window, and are divided into two categories;

1. All windows where the fall is four metres or more
2. Windows in bedrooms of Class 1, 2, 3 and 4 buildings, and any room in Class 9b Early Child Care Centres where the potential fall is two metres or more.

Safetyline Jalousie glass and aluminium louvres at their maximum span of 1400mm have passed the 125mm Pressure Plate Tests A & B (250N of horizontal force is applied to the centre and corners/weakest points of the window). The System also passed the additional bullet shaped probe test (250N of perpendicular force applied to the centre of all openings). The sphere probe was unable to pass through the louvre openings and there was no evidence of dislodgement.

Total Performance U-Value and SHGC Calculation to AFRC Lab Conditions (WERS)

An analysis has been undertaken to assess the overall thermal performance of the Safetyline Jalousie, JX louvre system. The analysis was undertaken with THERM 6.3, the Australian fenestration rating council (AFRC) total U-value and total solar heat gain coefficient (SHGC) of the vision panels has been calculated based on actual sizes.

Product	Panel Size (HxW)	Glazing	U-Value	SHGC	Air In
JX	1400x2700	6mm Clear Toughened	6.7	0.49	0.12
JX	1400x2700	6.38mm Clear Laminate	6.6	0.46	0.12
JX	1400x2700	6.38mm Grey Laminate	6.6	0.36	0.12
JX	1400x2700	6.38mm Comfortplus Clear	5.4	0.40	0.12
JX	1400x2700	6.38mm Comfortplus Neutral	5.4	0.31	0.12
JX	1400x2700	6.38mm Comfortplus Grey	5.4	0.30	0.12

Meets Balustrade Requirements

In addition to the above, Safetyline Jalousie louvres have also been impact load tested to **550kg**.

Safetyline Jalousie louvres are suitable for floor to ceiling applications and with their 106mm openings, meet all of the necessary requirements for use as balustrade without the need for any additional options or bars to be fitted. Balustrade screws are used for this application. Refer to [page 36](#) for additional information.

Loosening of Glass Louvre Bearer

Pull force of more than 200 daN (200kg) on bearers without loosening of louvres. Test no. Q-0305-01.

Sunlight Ageing

On end caps and drivers, after 300 hours in compliance with standard NF T51-056, no noticeable change in characteristics. CSTB test no. 01-0020.

Window Energy Rating Scheme (WERS)

Safetyline Jalousie is a member of the Window Energy Rating Scheme. Test results are available on request or by visiting the WERS website.

The Impact of Air Infiltration on Thermal Values

Inhabit Group were engaged by Safetyline Jalousie to undertake comparative modelling to quantify the impact of the reduced air infiltration of the Safetyline Jalousie window products compared to its competitors with higher air infiltration values.

The assessment compared the difference in façade gains and losses due to air infiltration and thermal transfer of the Safetyline Jalousie Louvers system, to its competitors. The assessment was undertaken against 2 competitors for both a residential (Class 2) and student housing (Class 3) scenario.

The focus of the study is to demonstrate a combined performance assessment.

Student Housing Energy Modelling

The results of the student housing assessment outlined in the table below found the Jalousie system to deliver the most preferential performance outcome.

	Type 1				Type 2			
	Northern Facing		Southern Facing		Northern Facing		Southern Facing	
	Heat Loss	Heat Gain	Heat Loss	Heat Gain	Heat Loss	Heat Gain	Heat Loss	Heat Gain
Brisbane	-11%	-1%	0%	-6%	-9%	-1%	0%-4%	
Melbourne	-13%	-1%	1%	-7%	-11%	-1%	1%-5%	
Sydney	-11%	-1%	0%	-7%	-10%	-1%	0%-5%	

Residential Energy Modelling

The residential modelling results do not achieve a preferential outcome of the Jalousie system. This can be attributed to:

- The lack of sensitivity in the analysis in regards to the inclusion of air infiltration of the window system;
- The inability of the Chennath engine to account for variations in panel size and whether a given system can be used in that application;
- The inability of the Chennath engine to account for variation in panel size and its impact on U-values.

The net result of the lack of sensitivity discussed above results in the Safetyline Jalousie system performing worse than their unframed counterparts in mandatory residential NCC compliance assessments. Despite the fact that using the Jalousie system will result in a preferential thermal comfort outcome, this is not a focus of residential compliance modelling.



Percentage Heat Gain and Loss for Windows Compared to Jalousie Benchmark

As such it can be concluded, that when modelled in detail, the performance benefits of the Jalousie product will be realised, however, it is acknowledged that there are a range of market barriers to the uptake of “accurate” modelling of the performance of the Jalousie systems.

The results of the student housing modelling found the Jalousie system to be preferential in all climate zones. This can be attributed to the higher resolution and flexibility of the modelling tools used for student housing analysis and generally for NCC building classes 3-9 (non-residential buildings including student housing, aged care and hotels).

It should be noted that there are two compliance pathways for non-residential building within the building code, deemed to satisfy (DTS) and JV3 performance solution.

When a DTS approach is used compliance for glazing is determined via the glazing calculator with the input being system U-value and SHGC. In this approach the benefits of reduced air infiltration of the Jalousie system will not be seen. However, if the glazing calculator is assessed using “actual panel sizes” the Jalousie products will be seen as superior to competitor’s products, due to its capacity to achieve larger spans.

When the JV3 verification pathway is adopted, an energy model of the project in undertaken. As this modelling is typically undertaken during the detailed design process, the specific glazing systems to be used may not be resolved. As such consultants will used assumed values to undertake modelling, resulting in the preferential performance of the Jalousie system not being considered in the analysis.

As such it can be concluded, that when modelled in detail, the performance benefits of the Jalousie product will be realised.

Louvre Performance Analysis of Learning Spaces

An energy modelling analysis was also conducted by Inhabit Group of Safetyline Jalousie louvre windows used in a school classroom application. Both a generic modular classroom building and a case study (Alexandria Park Primary school) were considered in Sydney, Brisbane, and Melbourne climates. The airtightness of Safetyline Jalousie louvre windows when compared to other products, and the effectiveness of natural ventilation using Safetyline Jalousie louvre windows, was studied.

The generic modular classroom formed the crux of the study and is present in identical or similar forms across both NSW and Australia. The case study model was used to provide further evidence of the trends identified and to test the applicability of the modelling approach in a real project.

Initial energy modelling results were mixed, due to the apparent conflict between airtightness and natural ventilation in each climate. The key findings of the initial energy modelling conclude that:

- Using Jalousie louvres can significantly increase the airtightness of a building, by between 7% and 20% for the cases tested.
- Using louvres for natural ventilation provides more outside air to learning spaces than required by minimum standards. For the cases tested, 9%, 24% and 12% more outside air was provided to learning spaces in Sydney, Brisbane, and Melbourne respectively.

Following the initial modelling, a revised louvre control strategy was developed as follows:

- Louvres are fully opened when the temperature outside is within a suitable (comfort) band and wind speed is sufficient to deliver the required outside air rate to the learning area.
- Louvres are partially opened at the 10% or 20% position for a wider band of temperatures to assist in removing heat from the learning areas. The required outside air rate is provided by mechanical ventilation. Air conditioning or heating is not operating (as the outside air + internal heat gains result in a suitable learning space temperature). We anticipate this wider temperature band to be 3°C to 5°C lower than the natural ventilation setpoint, however this wider band will be project specific.
- Louvres are closed (such that they achieve a high degree of airtightness) outside this wider setpoint band (i.e. when it is too hot or too cold outside).
- The required outside air rate is provided by mechanical ventilation. Air conditioning or heating is operating.

Through consideration of the revised control strategy, the following results were determined for the generic classroom level and case study respectively. For both cooling and heating dominated climates, a project specific analysis is recommended to optimise the louvre control systems and maximise benefits beyond the figures presented herein.

Summary of Case Study Results for Revised Controls Scenario

Data modelling by Inhabit Group of our Case Study Project using Safetyline Jalousie louvre windows proves that our system can increase thermal comfort levels for occupants, reduce ongoing energy usage and therefore costs and ultimately reduce greenhouse gas emissions for the operating life of the project.

Table 1

Metric	Sydney (scenario CSJ)	Brisbane (scenario CBJ)	Melbourne (scenario CMJ)
Annual Thermal Energy Use, % Saving	= 4% to 5%	= 4% to 5%	= 3.5%
Annual GHG Emission Savings KgCO _{2e} per Classroom	= 30 per classroom	= 50 per classroom	= 25 per classroom
Annual Electricity Savings, \$ per Classroom	=\$10 per classroom	=\$17 per classroom	=\$7 per classroom
Additional Ventilation Supplied % Above Requirement	= 11% to 14%	= 22% to 28%	= 4% to 10%

Based on a review of both the generic classroom level façade and the case study learning space facades, it was determined that approximately 15% of the façade consisted of louvres. NCC 2019 sets a façade air infiltration limit of 10 m³/m².h @ 50 Pa.

This figure was used for all façade elements other than the elements replaced by the Jalousie louvres. The airtightness of the façade area occupied by louvres was varied as per Table 1, which also shows the resultant whole of façade airtightness figure.

It is worth noting that the airtightness benefit of Jalousie louvres increases as the percentage façade area increases.

Summary of Generic Classroom Level Results for Revised Controls Scenario

Data modelling by Inhabit Group of Generic Learning Spaces using Safetyline Jalousie louvre windows utilising the Smart Air System proves that our system can increase thermal comfort levels for occupants, reduce ongoing energy usage and therefore costs and ultimately reduce greenhouse gas emissions for the operating life of the project.

Table 2

Metric	Sydney (scenario CSJ)	Brisbane (scenario CBJ)	Melbourne (scenario CMJ)
Annual Thermal Energy Use, % Saving	1.5%	1.7%	3.4%
Annual GHG Emission Savings KgCO _{2e} per Classroom	167 24 per classroom	340 49 per classroom	478 68 per classroom
Annual Electricity Savings, \$	\$54 \$8 per classroom	\$111 \$16 per classroom	\$123 \$18 per classroom
Additional Ventilation Supplied % Above Requirement	9%	24%	12%



Facade Airtightness Data

Data modelling by Inhabit Group proved that Safetyline Jalousie louvres have a much higher airtightness figure than the generic louvres tested or indeed the requirements of NCC 2019 and therefore increased the tested buildings overall air tightness by up to 20% and reduced the number of air changes per hour allowing for a much tighter control of the indoor air quality.

Table 3

Louvre type	Airtightness L/m ² .s @ 75 Pa as per AS 2047	Calculated* (scenario GBJ) m ³ /m ² .h @ 50 Pa	Resultant Whole-of-Façade Airtightness, m ³ /m ² .h @ 50 Pa	Relative Benefit of Jalousie Louvres
Jalousie Louvre	0.12	0.10	8.55	-
Generic Louvre A	1.5	1.23	9.16	7%
Generic Louvre B	1.9	1.55	9.34	8%
Generic Louvre C	5	4.08	10.70	20%
All Other Façade Elements (as per NCC 2019)	3.4	2.78	10.00	-

*Note: The façade industry standard metric of L/m².s @ 75 Pa was converted to the building energy industry standard metric of m³/m².h @ 50 Pa using a standard

flow exponent of 0.5. It is noted that Jalousie louvres have a much higher airtightness figure than the generic louvres tested, or indeed the requirements of NCC 2019.

A further scenario was created in an effort to address the control-related drawbacks of the initial scenario. The key outcomes of this revised scenario are that:

- Jalousie louvres are airtight, therefore they provide benefit during heating months.
- Jalousie louvres can be automatically operated so they are partially open during favourable conditions, providing benefit during cooling months. The partial opening of the louvres mimics the airtightness performance of the less airtight scenarios, however this is reproduced in a controllable fashion. A calculation of louvre opening position to mimic a lower level of airtightness resulted in an opening position of 10% to 20%.
- Louvres are fully opened when the temperature outside is within a suitable (comfort) band and wind speed is sufficient to deliver the required outside air rate to the learning area.

- Louvres are partially opened at the 10% or 20% position for a wider band of temperatures to assist in removing heat from the learning areas. The required outside air rate is provided by mechanical ventilation. Air conditioning or heating are not operating (as the outside air + internal heat gains result in a suitable learning space temperature). We anticipate this wider temperature band to be 3°C to 5°C lower than the natural ventilation setpoint, however this setpoint will be project specific.
- Louvres are closed (such that they achieve a high degree of airtightness) outside this wider setpoint band (i.e. when it is too hot or too cold outside). The required outside air rate is provided by mechanical ventilation. Air conditioning or heating are operating.

Note that the results of this scenario are considered conservative. A control system that is project specific and considers specific climate and heat gains will result in better performance.



SPECIFICATIONS

Safetyline Jalousie's Vacuum Glazed Louvre Window

The JX vacuum glazed louvre window offers architects, building designers and façade engineers the thermal performance of conventional double glazing. Using Pilkington's Spacia, the world's first commercially available Vacuum Glazing, it provides an attractive solution to improving energy efficiency all year round and with all of the same design capabilities as the original JX Safetyline Jalousie Louvre window.

How it Works

A vacuum glazed unit consists of an outer pane of low emissive glass and an inner pane of clear float glass, separated by a micro spacer grid of small pillars each measuring just 0.5mm diameter and set 20mm apart. This grid ensures that the two glass panes are kept a fixed distance apart. The edges of the unit are welded to achieve an airtight seal. During the course of vacuum glazing manufacture, the air in the space between the two panes of glass is extracted to create a vacuum via the extraction point (as opposed to filling the space with air or gas). Even a small vacuum is effective in reducing the conduction and convection heat losses, so the gap between the two panes can be reduced to just 0.2mm.

The result is an excellent thermal performance from a unit that is only slightly thicker than a single pane of glass.

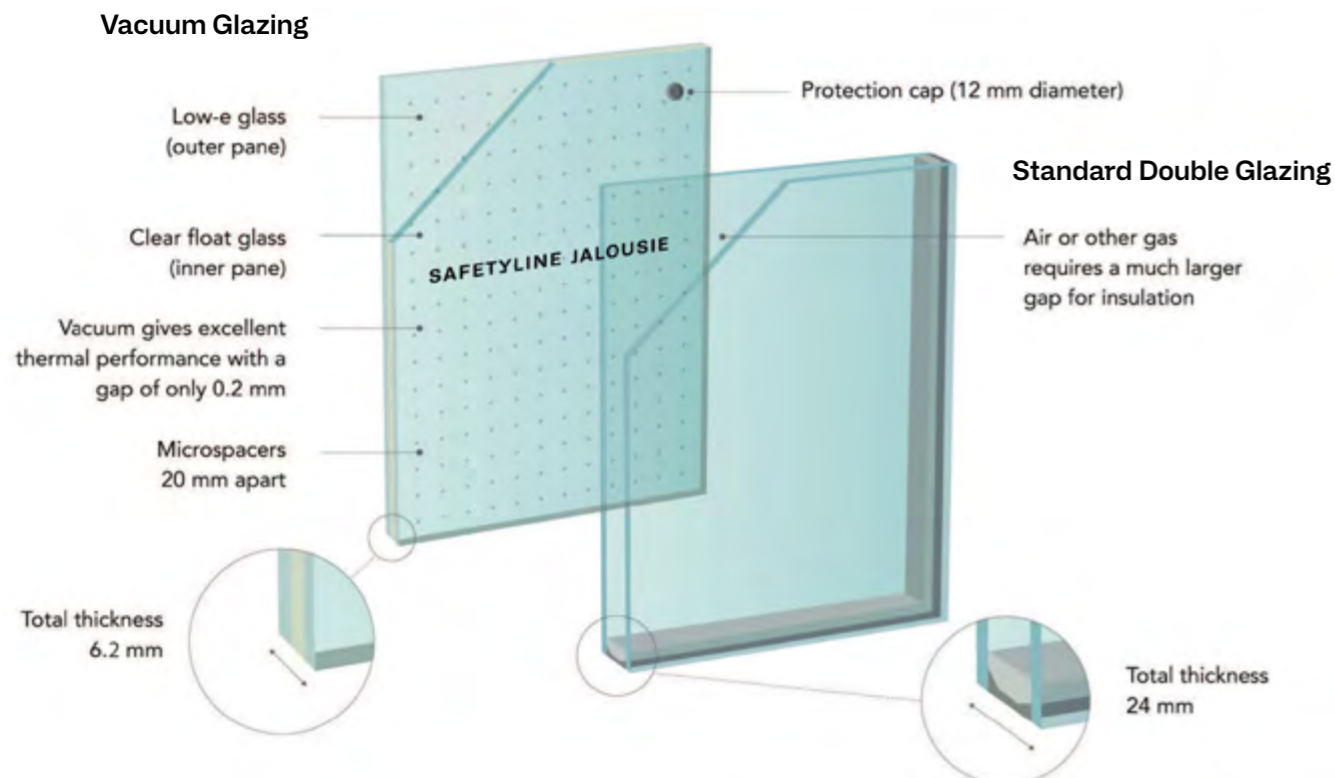

Total Performance U-value and SHGC to AFRC Lab Conditions Table

Product	Panel Size (H x W)	Glazing	U-Value	SHGC	Air In
JX	1400x2700	6.2mm Vacuum Glass	4.0	0.39	0.12

Acoustic Performance

Pilkington Spacia provides sound insulation to lock out noises generated inside and outside a room, creating the ultimate quiet environment.

The standalone acoustic rating provided by the manufacturer for Spacia 6.2mm is 34Rw.

Safetyline Jalousie louvres have been laboratory tested with 6mm Monolithic, 6.38mm Laminate and 6.52mm Laminate Hush (refer to test results on Page 17).

Safetyline Jalousie's results are equivalent or within 1dB of the manufacturer's sound insulation data. It can therefore be estimated that the minimum acoustic rating achieved for the Spacia glass incorporated into the Safetyline Jalousie louvre system is 33Rw.

Features and Specifications

- Each blade is encapsulated on 4 sides with no exposed edges
- Total thickness of glass 6.5mm
- Spans up to 1400mm
- Inbuilt security via the louvre bearer
- Weatherproofing provided by EPDM and polyethylene brush gaskets
- Cut down blades not available with this glass type* (refer to aluminium louvre heights charts on page 28 and 29 for this product.)
- Diameter of protection cap 12mm.

Specifying Safetyline Jalousie Louvre Windows in Bushfire Prone Areas



Australian Standard AS3959:2009 covers the bushfire safety requirements of building in bushfire prone areas. It is primarily concerned with improving the ability of buildings to better withstand the attack from bushfires thus giving a measure of protection to the building occupants as well as the building itself.

What are the Bushfire Attack Level (BAL) Ratings?

There are six BAL ratings. Each one indicates a higher level of risk than the one that precedes it – refer to the diagram above.

When specifying windows in bushfire prone areas, Safetyline Jalousie louvre windows can be used for all ratings up to BAL-29 without the protection of external screens or bushfire shutters. However, to ensure compliance, the following requirements for each Bushfire Attack Level must be met;

BAL – Low

- Standard window products can be used at this level so there are no specific requirements.

BAL - 12.5

- Internal screen must be used with aluminium mesh
- Glass louvres are to be fitted with aluminium end caps

BAL – 19

- Internal screen must be used with aluminium mesh
- Glass louvres are to be fitted with aluminium end caps
- 6mm toughened safety glass to be used

BAL – 29

- Internal screen must be used with aluminium mesh
- Glass louvres are to be fitted with aluminium end caps
- 6mm toughened safety glass to be used



Comprehensive Specification

The following specification is provided for convenience and non-applicable items should be deleted. The louvre window shall incorporate the single glazed series JX Louvre Window by Safetyline Jalousie (1300 86 3350) and manufactured to achieve specific ratings as per below and as required by Australian Standard AS2047.

- The louvre window shall be the JX by Safetyline Jalousie with 63mm extruded aluminium frame.
- The louvre window shall be capable of a maximum width of 1400mm.
- Each louvre shall be framed on three sides and hinged at the rear edge.
- Glass louvres should require at least 200kg pull out to remove the blades.
- Weatherproofing shall be provided by EPDM and polyethylene brush gaskets.
- Water drainage is to be via the bottom transom.

- The louvre window should be fitted with nylon end caps and capable of opening to 80° at an interval of 135mm.
- Additional security shall be provided by an 8mm stainless steel rod inserted into the louvre bearer.
- Internal fly screens should snap into the frame and be easily removed for cleaning.
- The louvre window shall be capable of achieving a minimum of 33 Rw Acoustic rating.
- The louvre window shall be capable of reaching 800pa water penetration rating.
- The louvre window shall be capable of achieving an air infiltration rating of 0.12 L / Sqm / S.
- The louvre window shall be capable of complying with Balustrade and fall prevention requirements.
- Reinforcement of louvre articulations shall be included for use as balustrade.

Standard Heights – Glass Louvres

- Wherever possible, standard heights should be used.
- Should standard heights not be used a cut down blade is required. If this blade is less than 60mm the opening would need to be adjusted to standard heights.
- Each lever will only lift a number of louvres depending on the type and length. (Refer to page 34)
- Where one louvre meets the other, and a new lever is required, an intermediate transom is used. This is marginally wider than the normal blade holder and the louvre above that join is 20mm smaller.

Applies to Glass Louvre Width up to 1400mm

No of Louvres	Frame Height with 7792 (mm)	Opening Height with Sub-Head (7657) & Sub-Sill (7710)
2	334	359
3	469	494
4	604	629
5	739	764
6	874	899
7	1009	1034
8	1144	1169
9	1279	1304
10	1414	1439
11	1549	1574
12	1684	1709
13	1819	1844
14	1954	1979
15	2089	2114
16	2224	2249
17	2359	2384
18	2494	2519
19	2629	2654
20	2764	2789
21	2899	2924
22	3034	3059
23	3169	3194
24	3304	3329
25	3439	3464
26	3574	3599
27	3709	3734
28	3844	3869
29	3979	4004
30	4114	4139



Standard Heights – Vacuum Glass and Aluminium Louvres

- Standard heights must be used with aluminium louvres as it is not possible to produce a cut down louvre.
- Each lever will only lift a number of louvres depending on the type and length. (Refer to page 34)
- Where one louvre meets the other and a new lever is required an intermediate transom needs to be used. This will impact on the overall frame height.

Applies to Vacuum Glass and Aluminium Louvre Width up to 1000mm

No of Louvres	Frame Height with 7792 (mm)	Opening Height with Sub-Head (7657) & Sub-Sill (7710)	Intermediate Transom
2	334	359	0
3	469	494	0
4	604	629	0
5	739	764	0
6	874	899	0
7	1009	1034	0
8	1144	1169	0
9	1279	1304	0
10	1414	1439	0
11	1549	1574	0
12	1704	1729	1
13	1839	1864	1
14	1974	1999	1
15	2109	2134	1
16	2244	2269	1
17	2379	2404	1
18	2514	2539	1
19	2649	2674	1
20	2784	2809	1
21	2919	2944	1
22	3054	3079	1
23	3209	3234	2
24	3344	3369	2
25	3479	3504	2
26	3614	3639	2
27	3749	3774	2
28	3884	3909	2
29	4019	4044	2
30	4154	4179	2

Standard Heights – Vacuum Glass and Aluminium Louvres (cont.)

Applies to Vacuum Glass and Aluminium Louvre
Width Greater than 1000mm

No of Louvres	Frame Height with 7792 (mm)	Opening Height with Sub-Head (7657) & Sub-Hill (7710)	Intermediate Transom
2	334	359	0
3	469	494	0
4	604	629	0
5	739	764	0
6	874	899	0
7	1009	1034	0
8	1144	1169	0
9	1299	1324	1
10	1434	1459	1
11	1569	1594	1
12	1704	1729	1
13	1839	1864	1
14	1974	1999	1
15	2109	2134	1
16	2244	2269	1
17	2399	2424	2
18	2534	2559	2
19	2669	2694	2
20	2804	2829	2
21	2939	2964	2
22	3074	3099	2
23	3209	3234	2
24	3344	3369	2
25	3499	3524	3
26	3634	3659	3
27	3769	3794	3
28	3906	3929	3
29	4039	4064	3
30	4174	4199	3



Intermediate Transom 7798

(for glass & aluminium louvres)

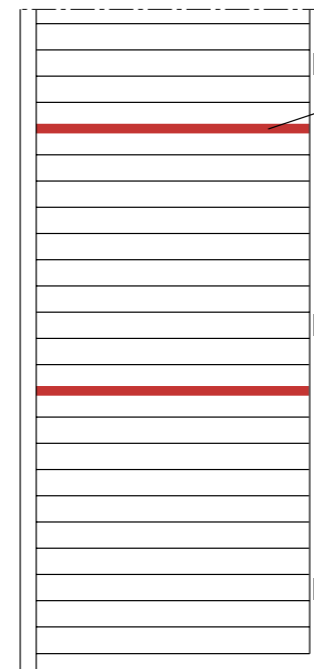

Intermediate transom required for more than 11 louvres

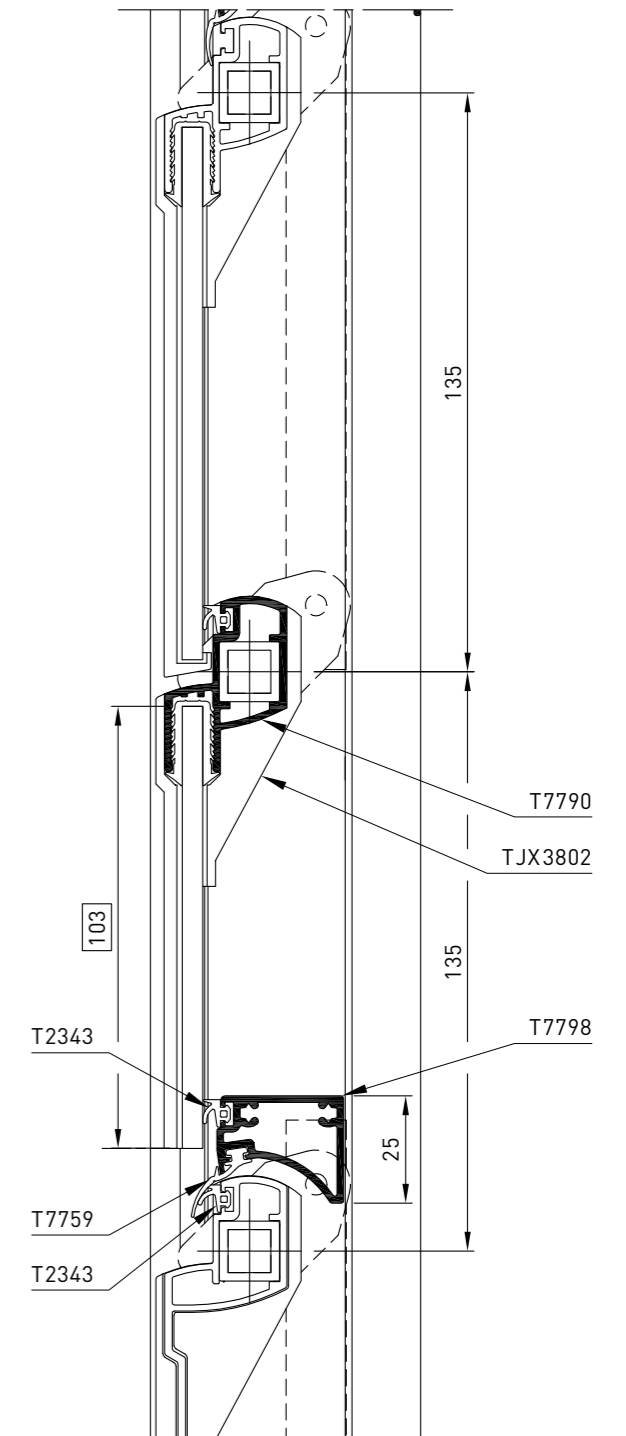

Standard Lever and External Motor Operation SLJ01 EXT

(for glass & aluminium louvres)

Louvre Width (mm)	400	600	800	1000	1200	1400
No Louvres	Number of Levers/Motors Required					
3	1	1	1	1	1	1
4	1	1	1	1	1	1
5	1	1	1	1	1	1
6	1	1	1	1	1	1
7	1	1	1	1	1	1
8	1	1	1	1	1	1
9	1	1	1	1	2	2
10	1	1	1	1	2	2
11	1	1	1	1	2	2
12	2	2	2	2	2	2
13	2	2	2	2	2	2
14	2	2	2	2	2	2
15	2	2	2	2	2	2
16	2	2	2	2	2	2
17	2	2	2	2	3	3
18	2	2	2	2	3	3
19	2	2	2	2	3	3
20	2	2	2	2	3	3
21	2	2	2	2	3	3
22	2	2	2	2	3	3
23	3	3	3	3	3	3
24	3	3	3	3	3	3
25	3	3	3	3	3	3
26	3	3	3	3	3	3
27	3	3	3	3	3	3
28	3	3	3	3	3	3
29	3	3	3	3	3	3
30	3	3	3	3	3	3



Internal Motor Operation TJX3701 INT

(for glass louvres)

Louvre Width (mm)	600	800	1000	1200	1400
No Louvres	Number of Levers/Motors Required				
12	1	1	1	1	1
13	1	1	1	1	2
14	1	1	1	2	2
15	1	1	2	2	2
16	1	2	2	2	2
17	2	2	2	2	2
18	2	2	2	2	2
19	2	2	2	2	2
20	2	2	2	2	2
21	2	2	2	2	2
22	2	2	2	2	2



Internal Motor Operation TJX3701 INT

(for aluminium louvres)

Louvre Width (mm)	600	800	1000	1200	1400
No Louvres	Number of Levers/Motors Required				
12	1	1	1	1	1
13	1	1	1	1	1
14	1	1	1	1	1
15	1	1	1	1	1
16	1	1	1	1	1
17	1	1	1	1	1
18	1	1	1	1	1
19	1	1	1	1	2
20	1	1	1	2	2
21	1	1	2	2	2
22	1	2	2	2	2

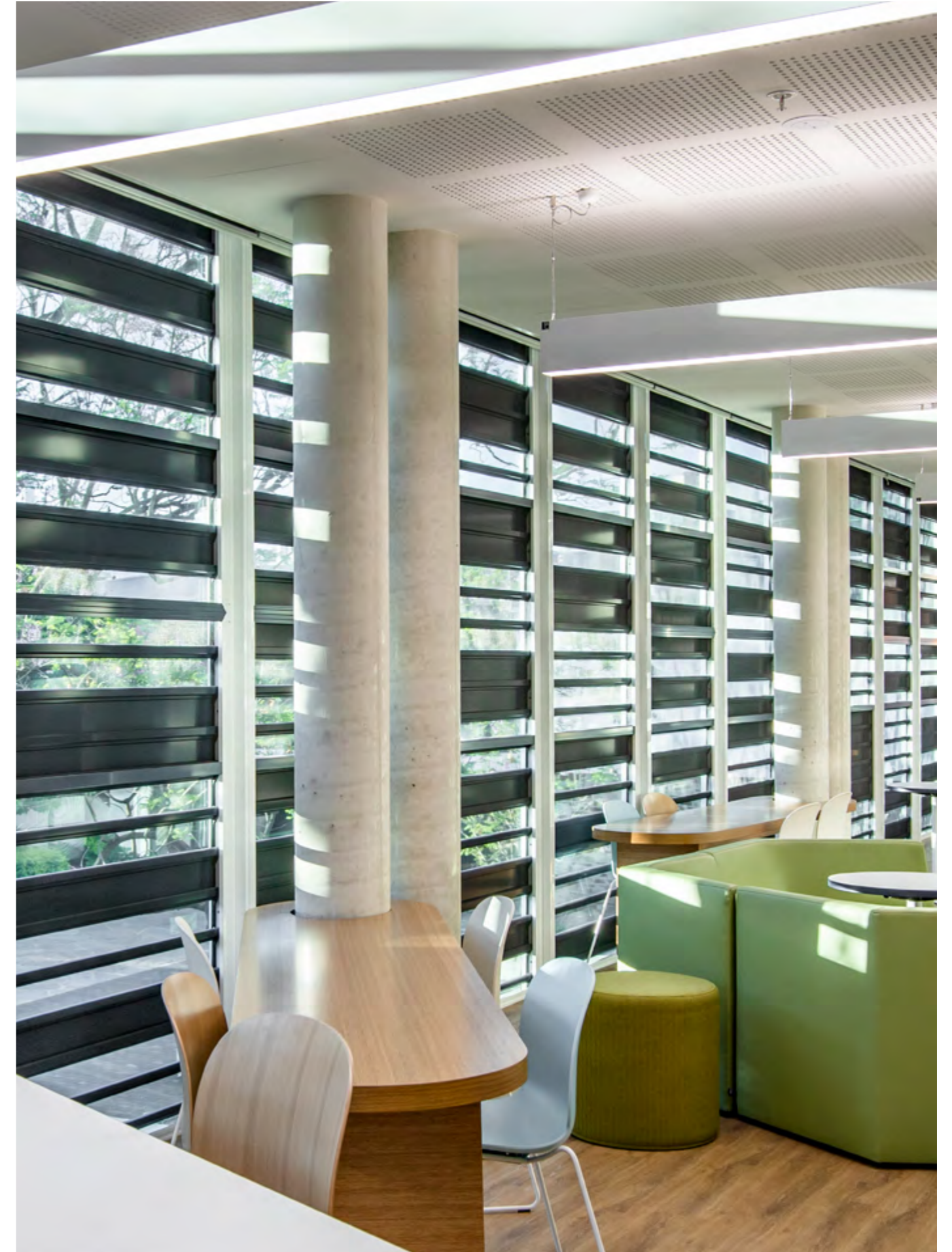



Choice of Handles

Reversible Operator Set T1197

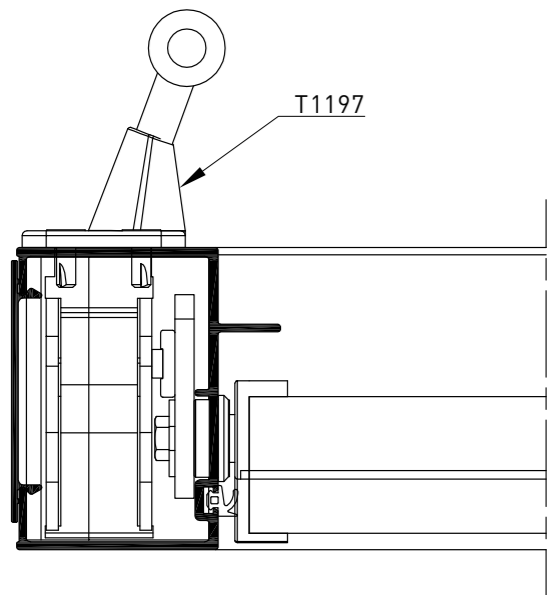

Lever Mechanism T1268 (R) or T1249 (L)
+ Nut Set TKV04

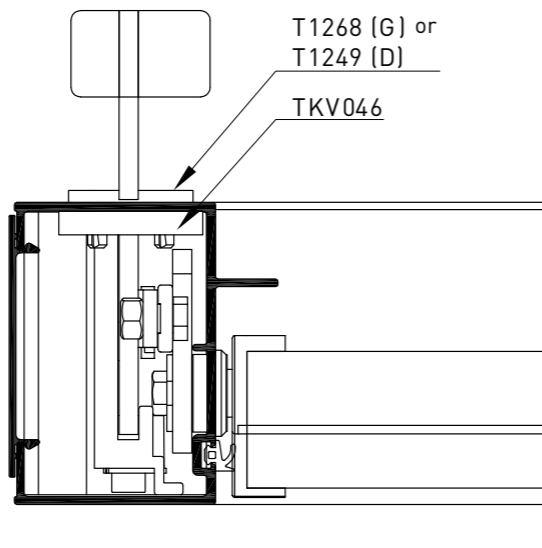

Handle TVT6002 + Drive Set TJX6002

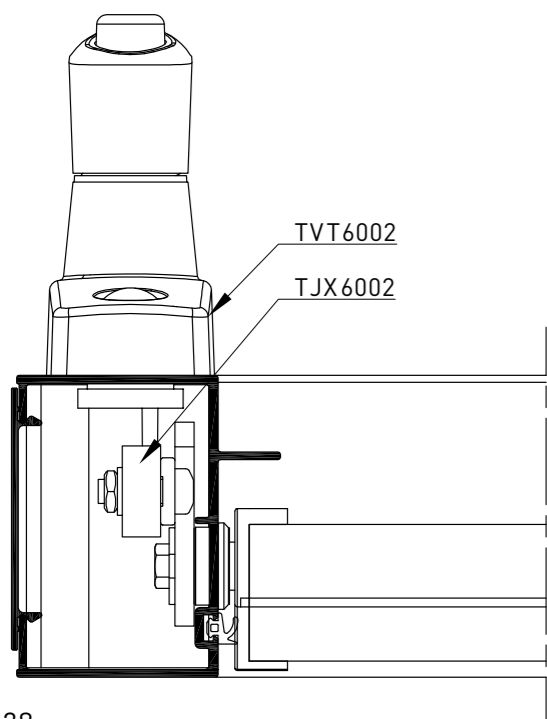

Winch Operator Set TVT6000 + Drive Set TJX6002

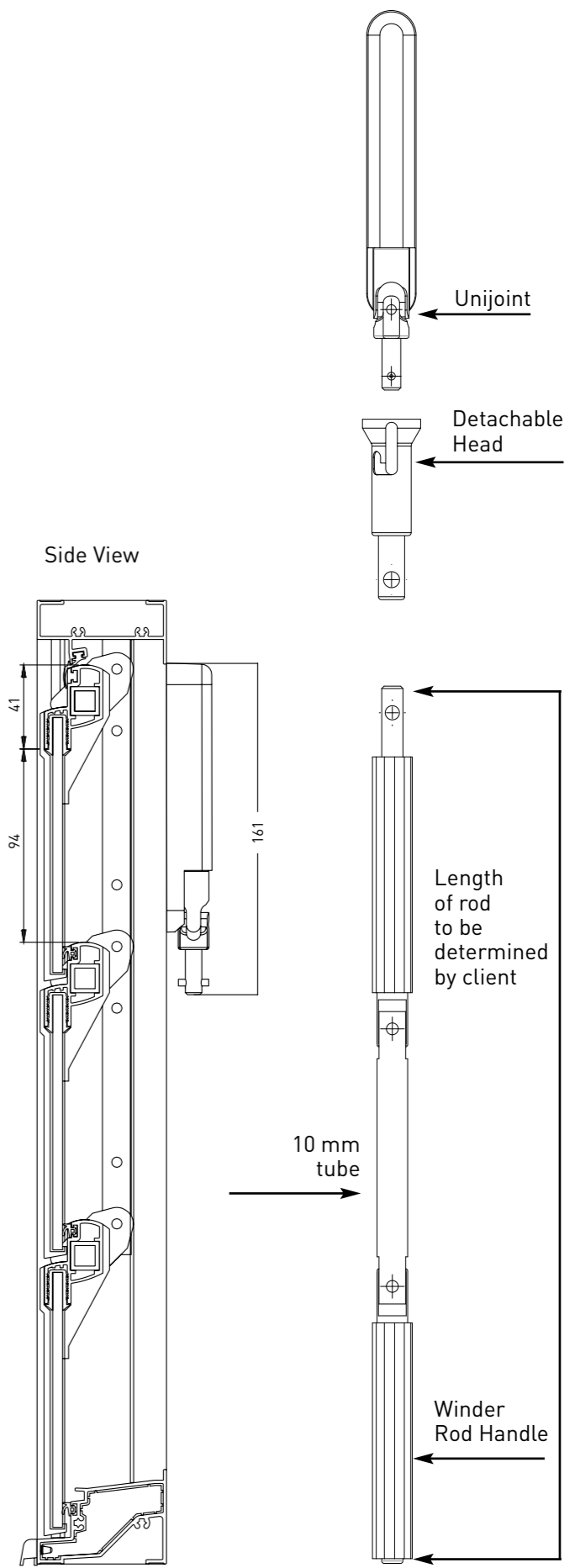
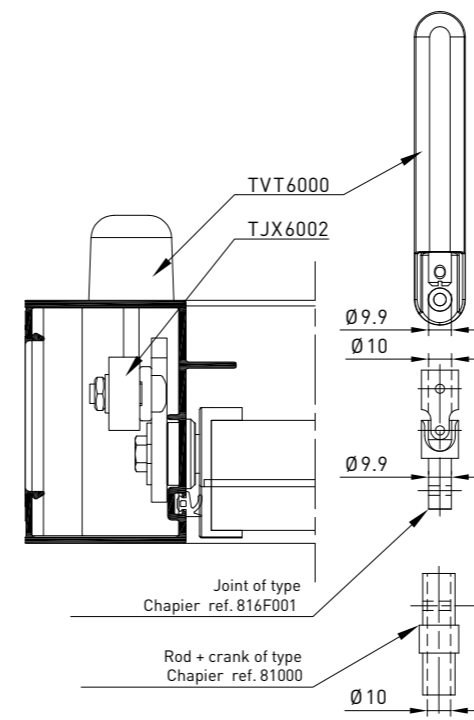
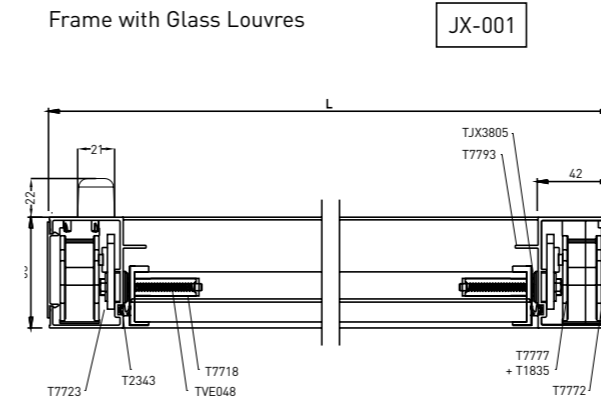



Frame Joint

Reinforcer for use as Balustrade

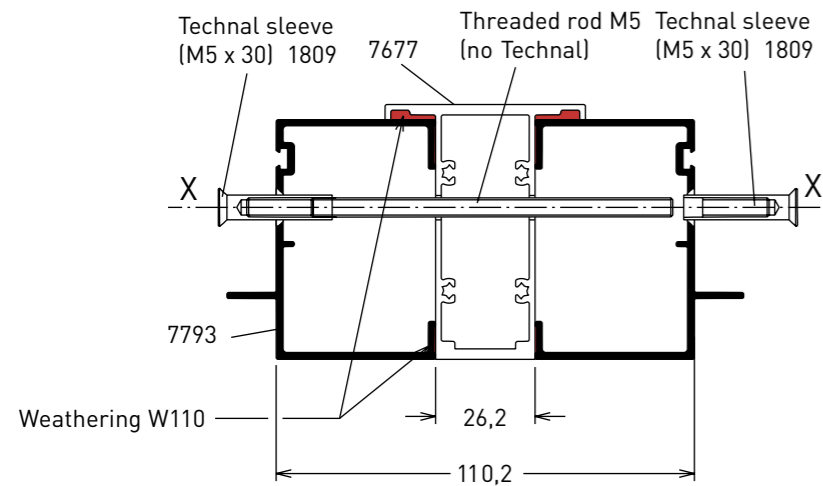
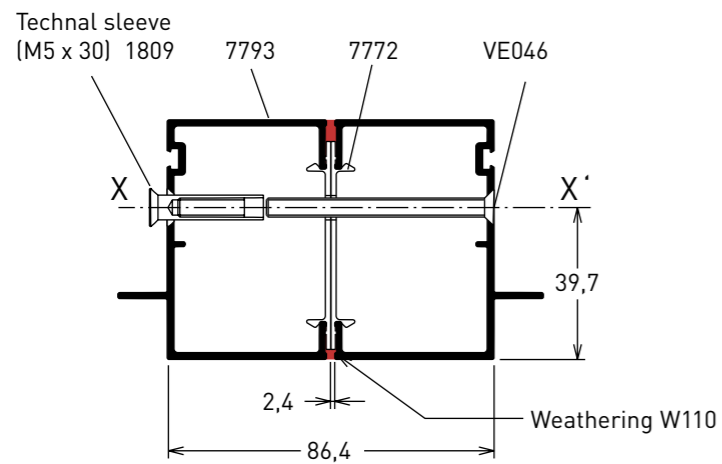
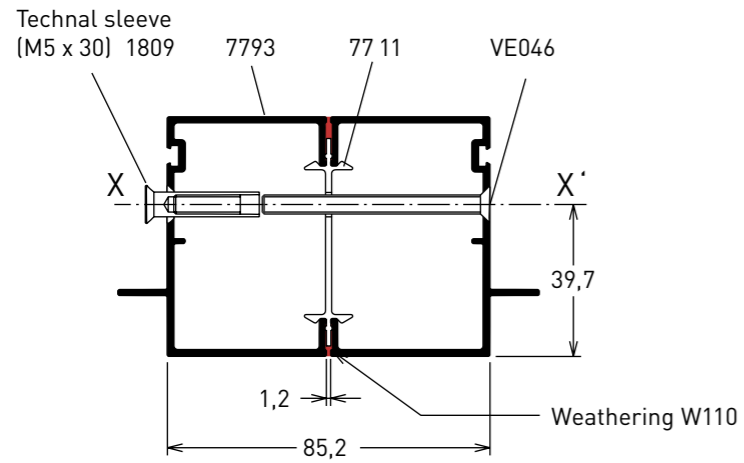

Manual operator.
Screw TVE017 mandatory for use of frame as guardrail.

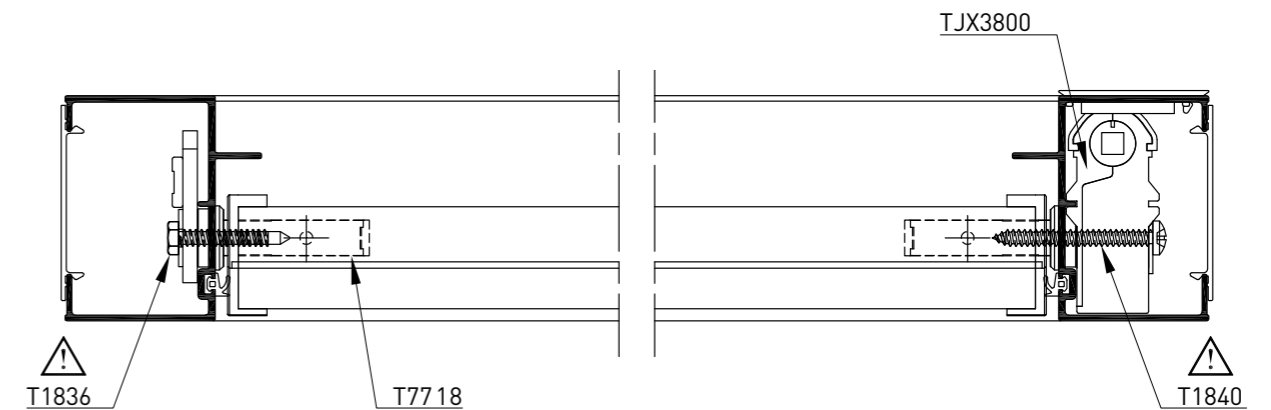
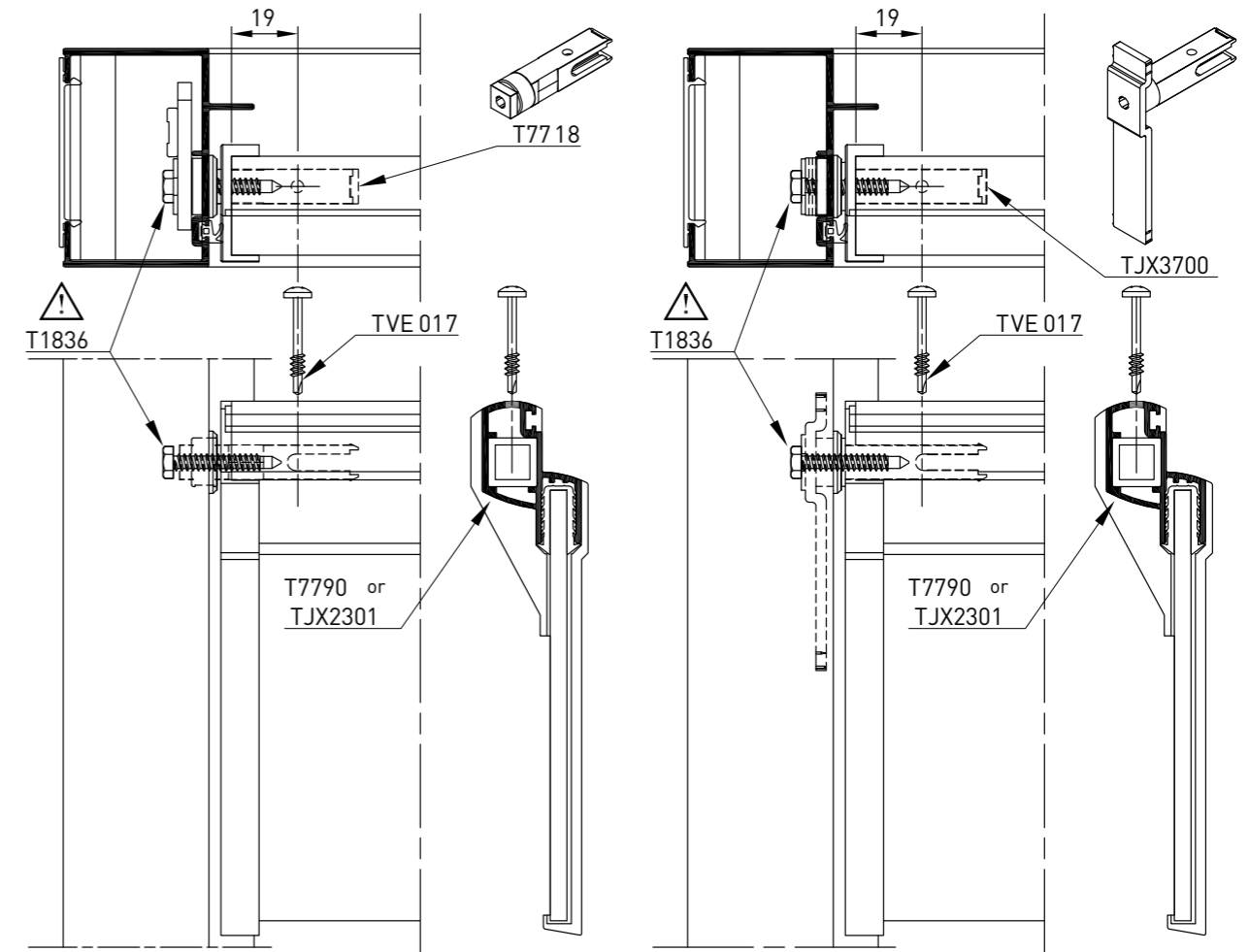

AUTOMATION

Whilst louvre windows provide the perfect natural ventilation solution there will be occasions when an automation solution is required. This could be as a result of windows being situated out of reach or more importantly where the louvres are to form part of a buildings natural ventilation strategy or smoke relief system.

The SLJ01 EXT Drive is installed and tested before the louvres leave the factory. With no visible moving parts, these actuators are designed specifically to operate Safetyline Jalousie louvres for optimum performance.

The louvres and controls form part of a complete solution and when the opportunity presents itself in combination with Safetyline Jalousie automation partners, we can assist to design a solution to meet almost any outcome.

Project specific trap hazard risk assessments are offered to ensure a safe and compliant system is offered to the end client.

System Elements can include:

- User interface via a touch sensitive wall switch, android or Apple device control through our intelligent controllers or full integration with home or building automation systems (BMS).
- Power failure battery back up to ensure louvres can always be closed.
- Climate control through multiple sensory devices such as, wind, rain, CO, humidity, temperature, etc.
- Automatic closing on power failure or change in weather condition.
- Night and or Morning purge to replenish stale air while cooling the fabric of the building to extend the time before traditional air-conditioning is required, thus reducing the buildings energy cost.
- 24/7 programmable timer to ensure louvres are closed at the end of each day.
- Intelligent control panels are fully programable and can be reconfigured if the building usage changes, the systems can also be easily expanded and networked later if required.



Smoke Control

In addition to the above functionality, the SLJ01 EXT Drive in combination with our partner's control systems provide a comprehensive EN12101 tested and compliant smoke control solution. All systems are fully equipped with the necessary failsafe elements including monitored 72-hour failsafe battery backup, with fault reporting back to the FIP and BMS.

The Smoke Relief Solution comprises 4 major components: Louvres, drives, cabling and controls which interface with the fire indicator (FIP) and building management system (BMS). The automation hardware is certified to EN12101 parts 2 & 10.

While the majority of our partner's systems can be used for both natural ventilation via integration with the BMS and or localised switches and FIP integration (Priority 1), the OSloop system has been specifically designed for use with Stairwell

Pressurisation and Powered Shaft systems, where only the fire floor automatic opening vents (AOV's) are opened, while all other building levels remain closed. This system has been designed to reduce the required amount of field cabling and power supplies substantially, thus reducing the overall installation cost. Systems can be integrated with the buildings fire indicator panel or alternatively they can operate on a standalone basis with their own smoke detectors and manual control points.

The SLJ01 EXT Drive has a standard 12month/15,000 cycle warranty, if these are controlled by our BlueSquared control systems, they will automatically take up the actuator warranty and increase this to 36months/15,000 cycles or whichever occurs first at no additional cost.



TJX3701 Internal Drive Features

The TJX3701 drive is concealed inside the window frame and optimises opening and closing operations to improve user comfort. This motor option is ideal for out of reach locations and where no visible operating mechanism is preferred.

Access to the motor is facilitated via a cover plate in the mullion which means there is no need to remove the window should maintenance be required.

A single motor can power up to 18 aluminium louvres or 12 glass louvres and has been endurance tested over 30,000 cycles.

Wire or radio remote control is available as well as the option to operate via smartphone or tablet.

- Power Supply DC 12V
- Low electrical consumption (10W)
- Limit switch control integrated
- Option of connecting to central control system
- 3 Year guarantee

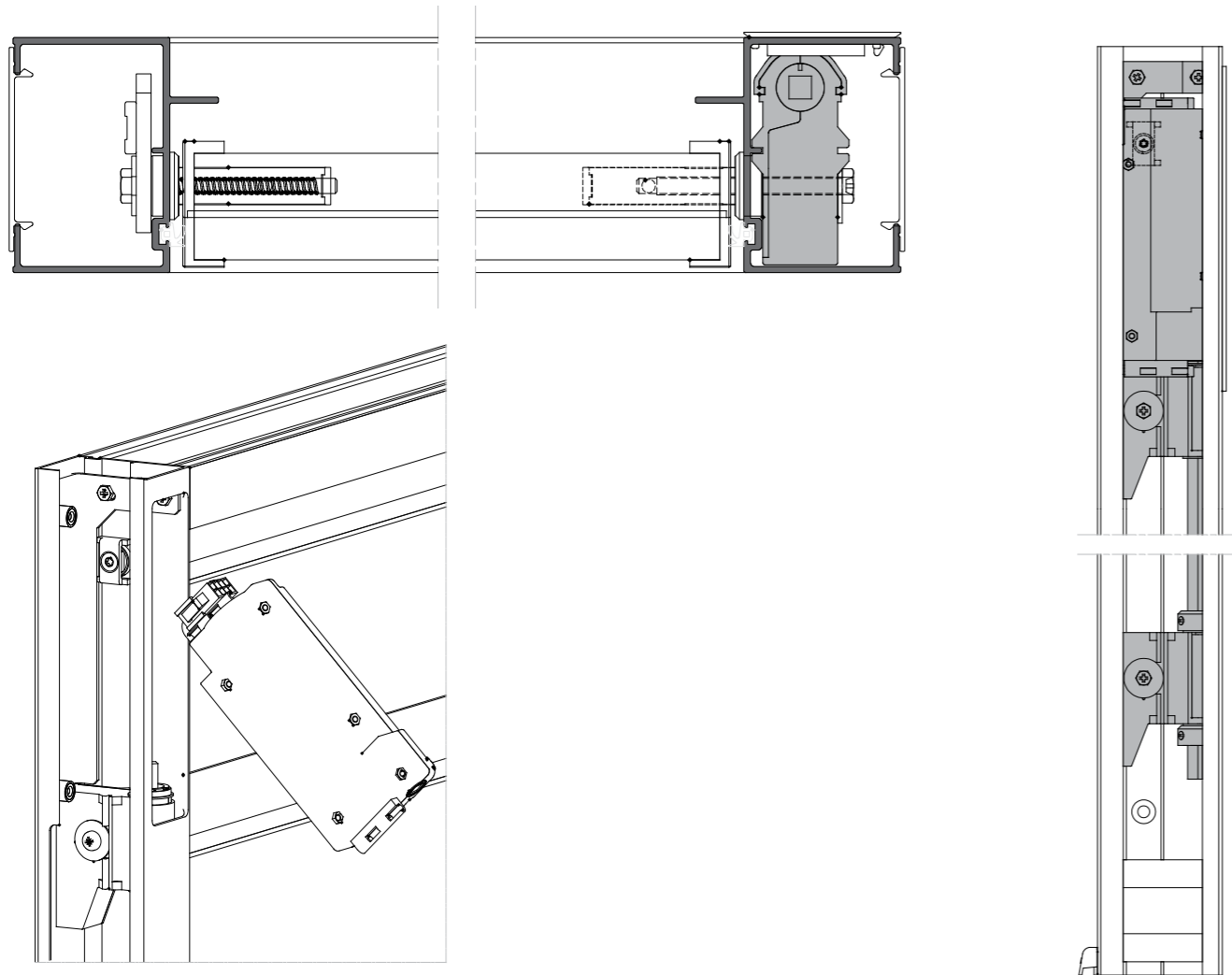

SLJ01 EXT Drive Features

The SLJ01 EXT Drive is mounted on the frame and has been specifically designed to operate the Safetyline Jalousie Louvre system for natural and smoke ventilation when used in conjunction with compliant controls.

The SLJ01EXT drive has a built in safety feature that will stop the actuator in the closing cycle should a foreign object interfere with the louvre blades.

Wire or radio remote control is available as well as the option to operate via smartphone or tablet.

- Powder coated or anodised colour matched body cover with no visible fixings
- Power Supply DC 24V +/- 15%, Cut off current 0.8A

- 1000N Opening force
- Stroke – 28mm (Factory Adjustable)
- Run Speed 2.2mm/s (Factory Adjustable)
- Duty Cycle 30% in 10 mins
- Open/Close relay (NC) Switching capacity 50mA
- 1yr/15,000 cycle manufacturer's warranty (whichever occurs first)
- Warranty extended to 3 years if compatible control solutions are supplied by Blue Squared Window Automation.

Motor Mounted on Frame

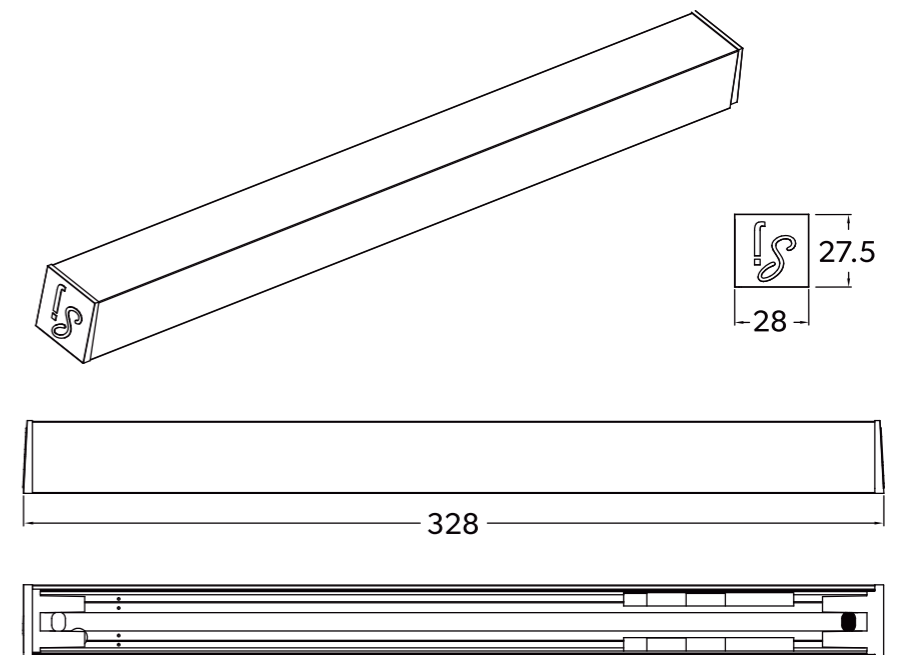
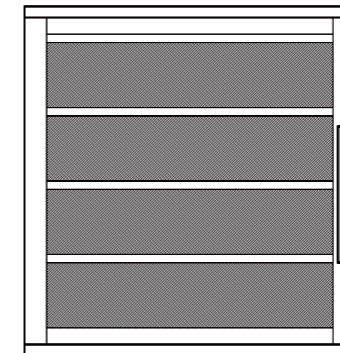

INSTALLATION

The installation methods for Safetyline Jalousie louvres will vary slightly depending on the type of construction however, there are 4 key steps to always follow:

- 1. Square and plumb.** This will ensure the functionality of the system.
- 2. Packing.** Packing between the window and building frame ensures that the frame remains square and plumb and adds strength to the screw fixing.
- 3. Fixing.** The window needs to be fixed correctly to enable the system to withstand the wind loads applicable to the site.
- 4. Flashing.** Windows should be flashed to stop water penetration around the outside of the system.

Safetyline Jalousie louvre windows provide easy and fast installation using counter sunk screws through the pre punched holes in the upright sections otherwise the windows can be supplied with a fin section for installation with timber reveals.

It is the installer's responsibility to provide the required window dimensions at the time of order and ensure that adequate clearance has been allowed.

Safetyline Jalousie louvres are sealed on all four sides and water is drained from the slots in the sills. Weathering deflectors are fitted over the drainage holes as shown below.

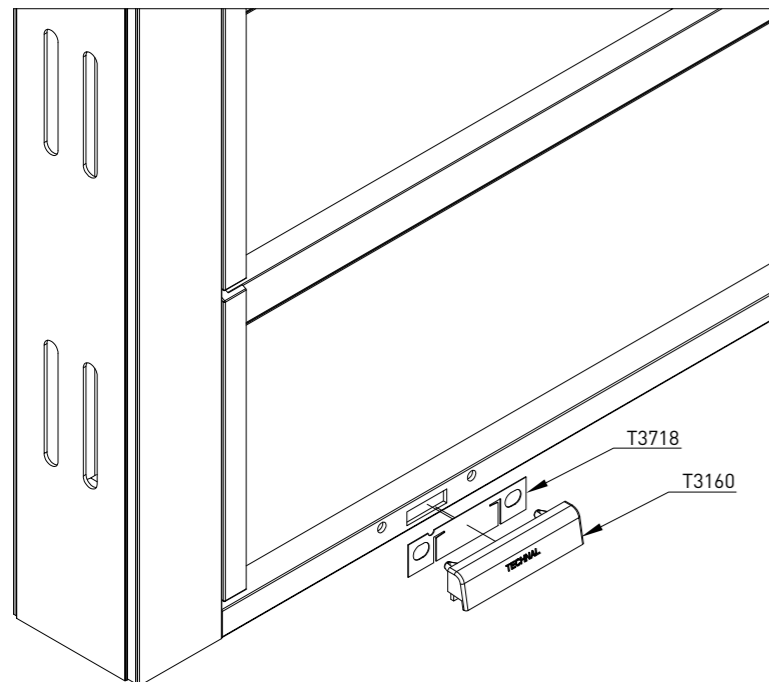

VARIOUS FIXING EXAMPLES

Timber Reveal

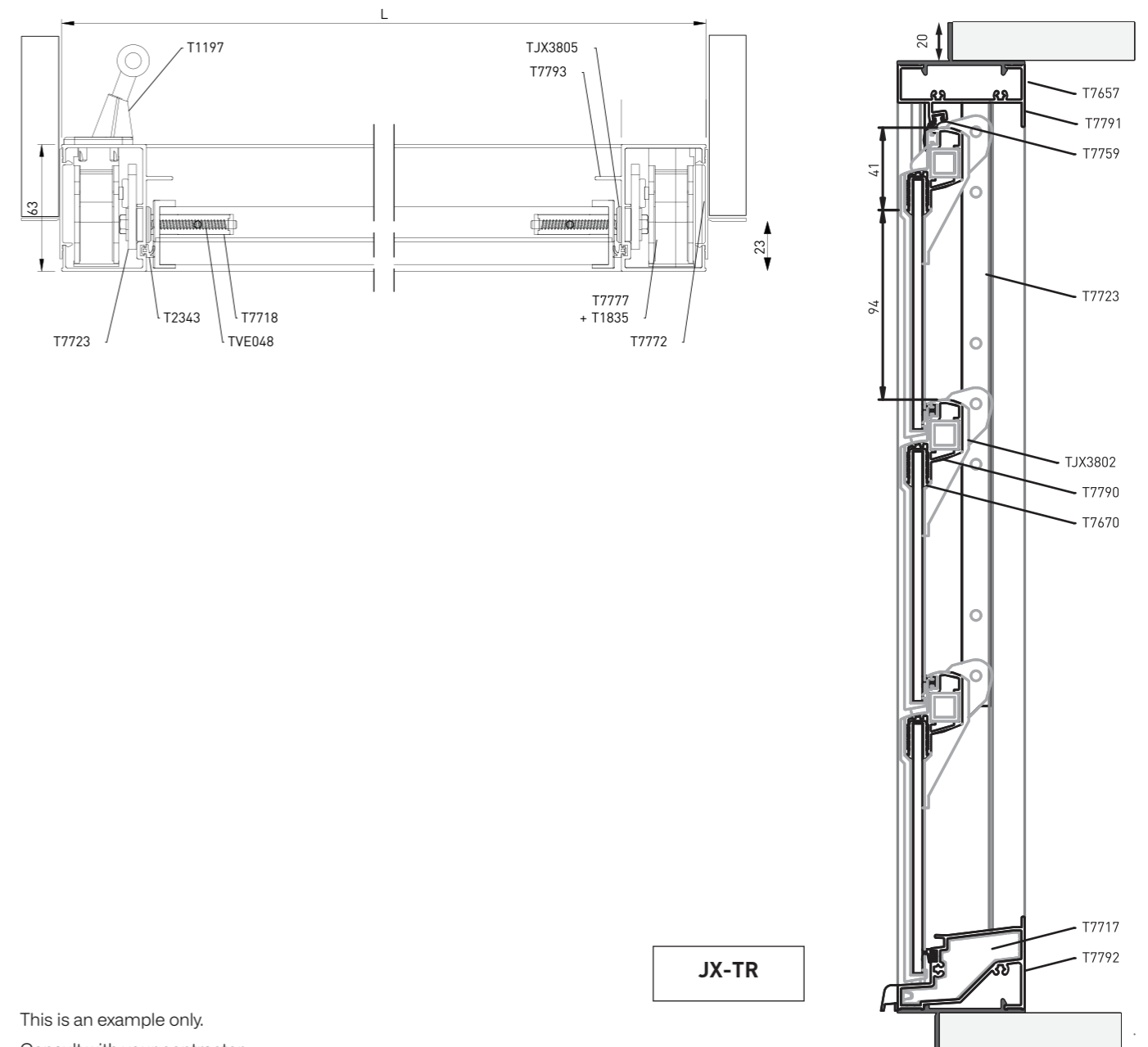

This is an example only.
Consult with your contractor
or installer for specific project
requirements

Brick Veneer

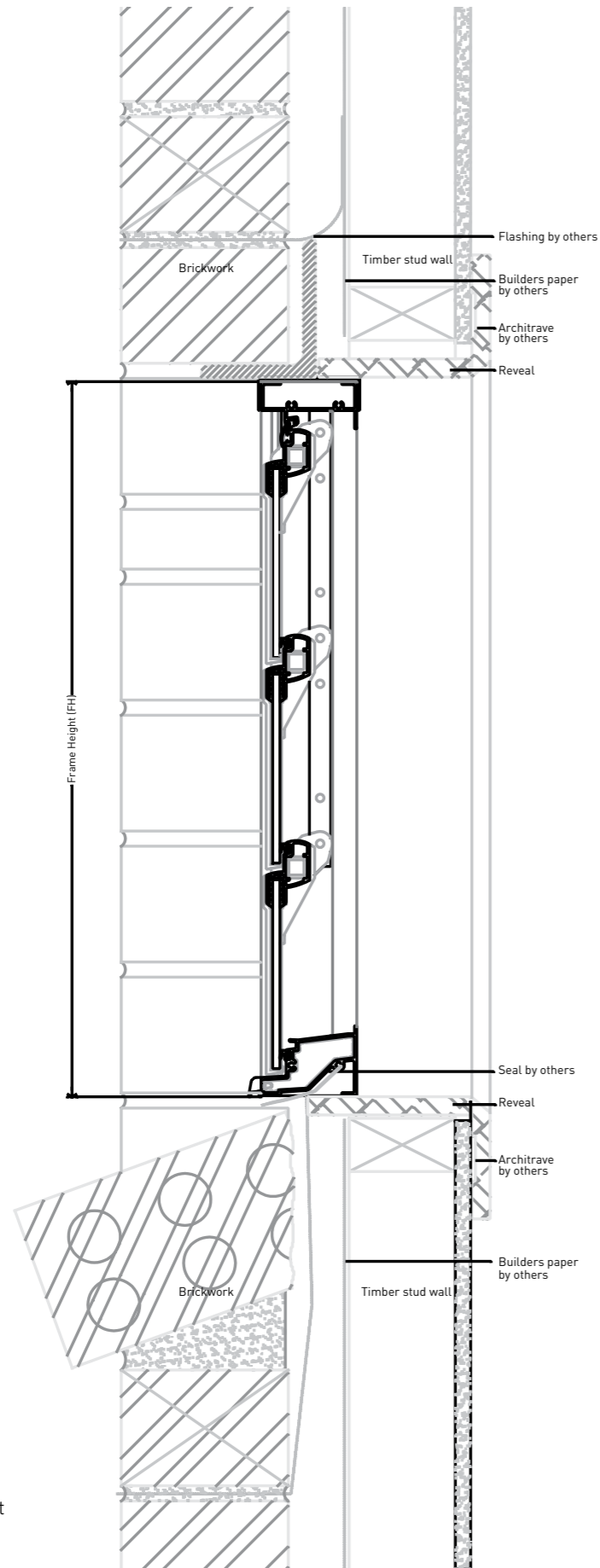

JX-BV

This is an example only.
Consult with your contractor
or installer for specific project
requirements



Stud Cladding

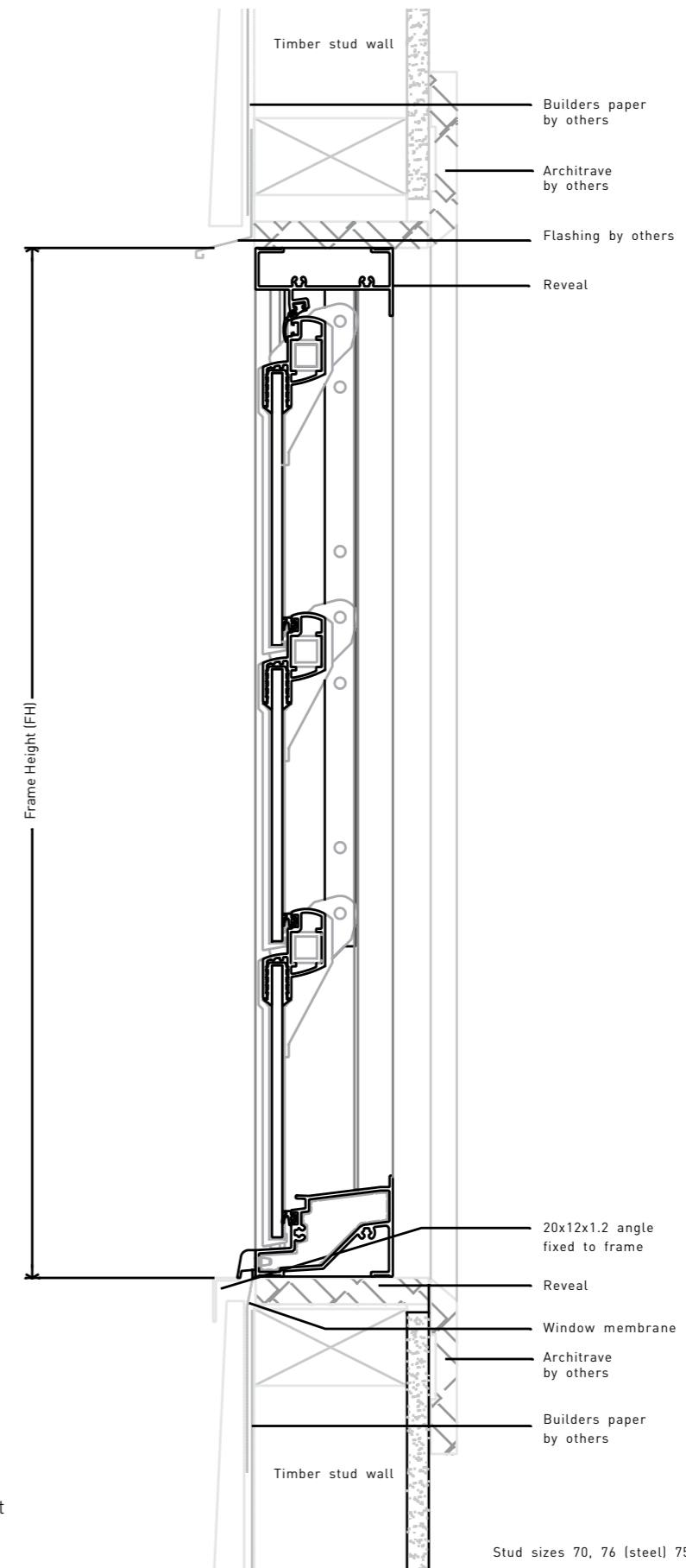

JX-SC

This is an example only.
Consult with your contractor
or installer for specific project
requirements

Stud sizes 70, 76 (steel) 75, 90 & 100



Blockwork - Sill Block

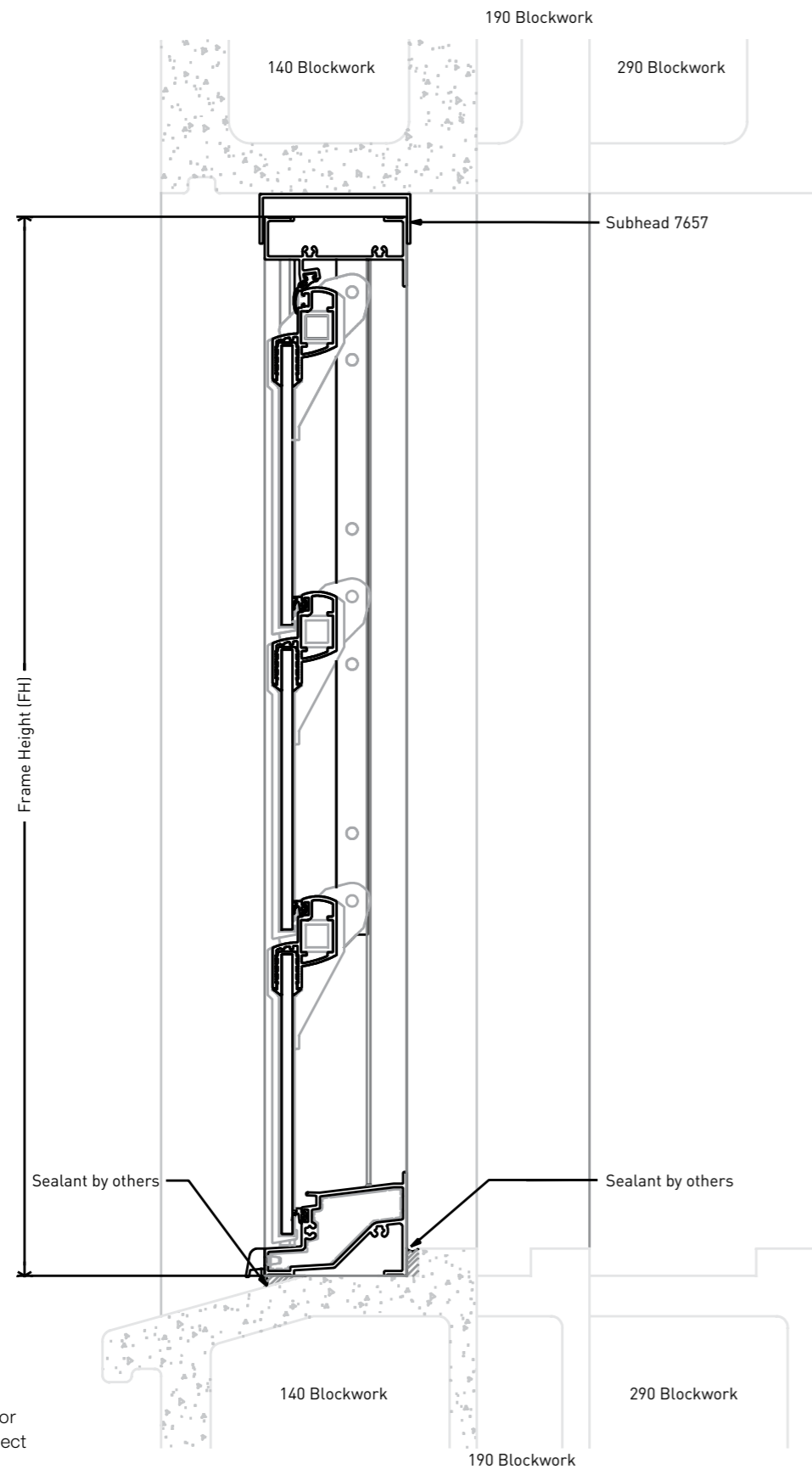

This is an example only.
Consult with your contractor
or installer for specific project
requirements

JX-BSB

Blockwork – Flat Sill

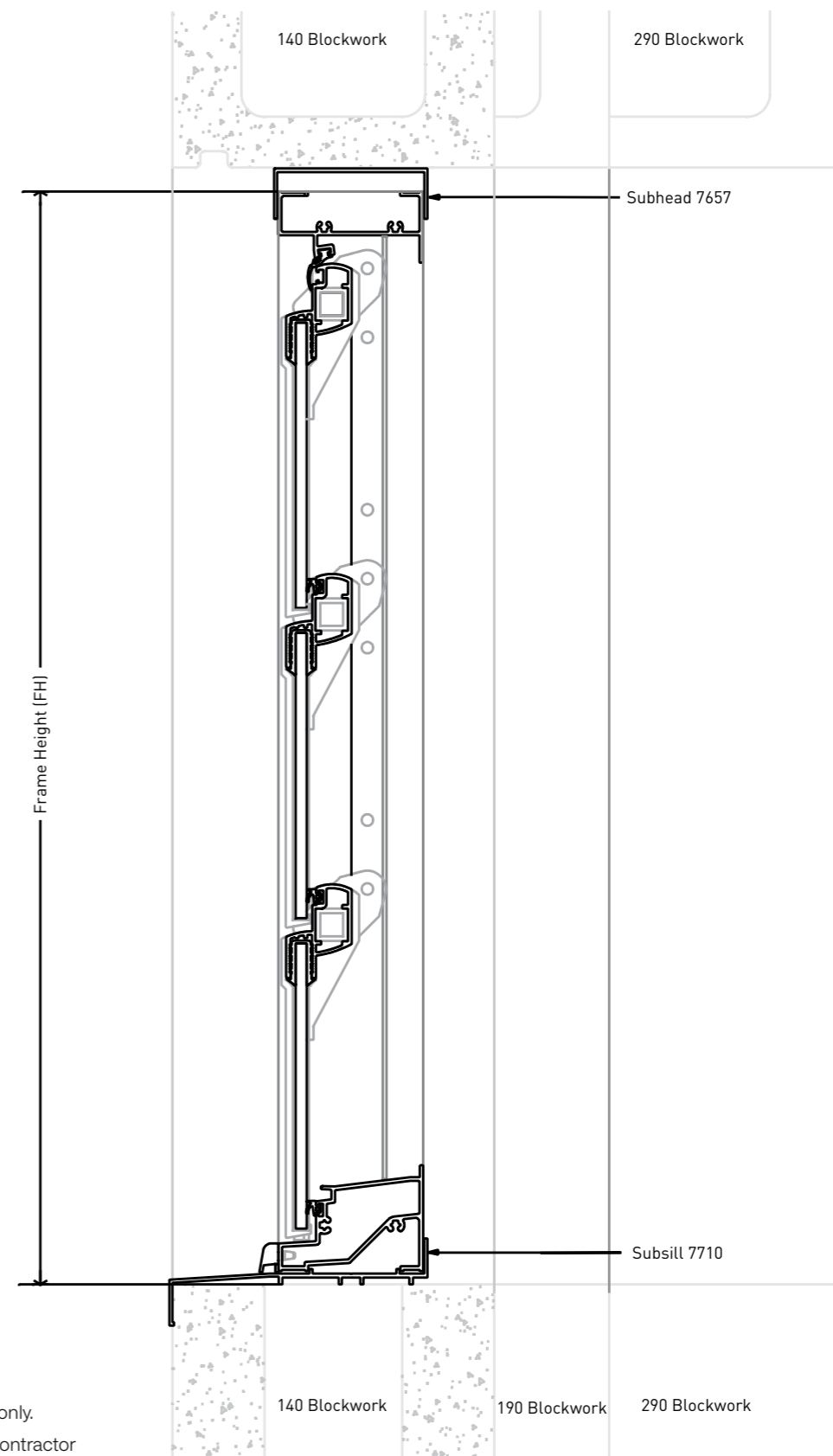

This is an example only.
Consult with your contractor
or installer for specific project
requirements

JX-BFS



Brick Double – Flat

Double Brick - Sill

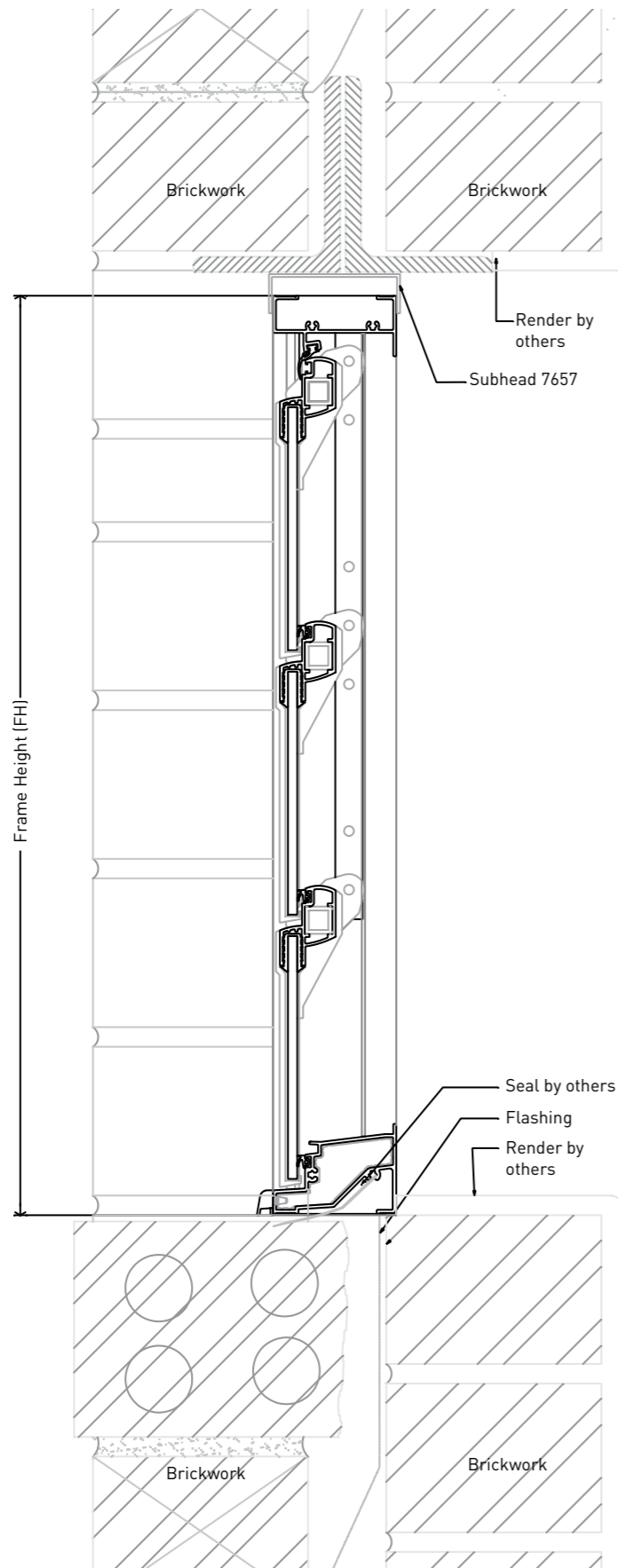

JX-BDF

This is an example only.
Consult with your contractor
or installer for specific project
requirements

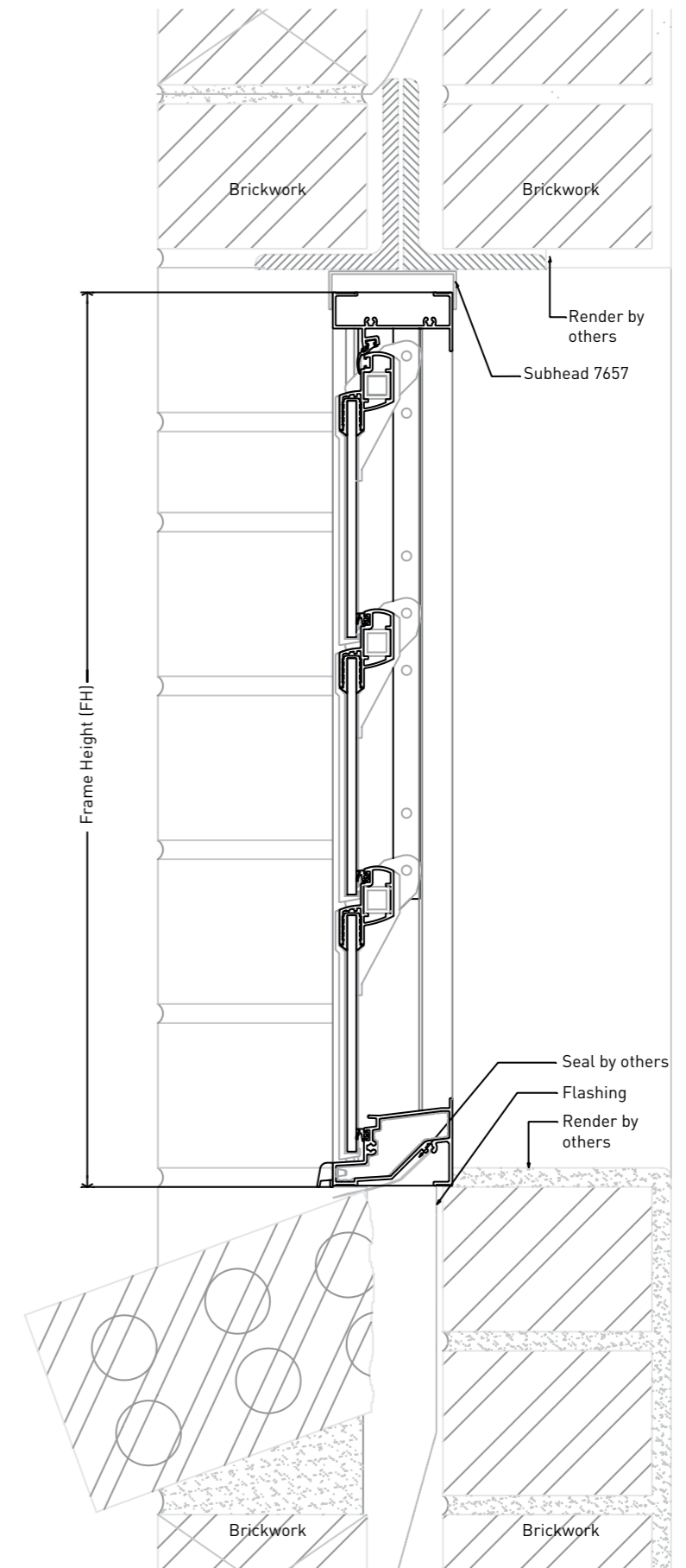

JX-BS

This is an example only.
Consult with your contractor
or installer for specific project
requirements



Integration with Aluminium Sub-Frame

Timber Frame

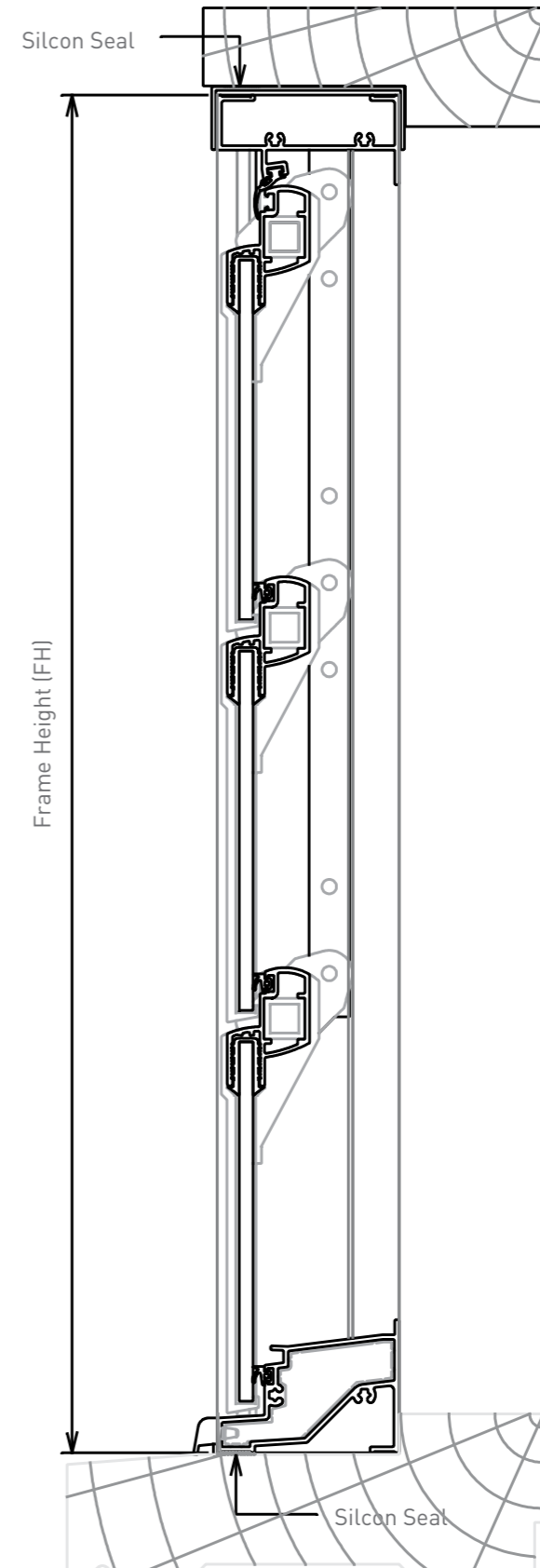
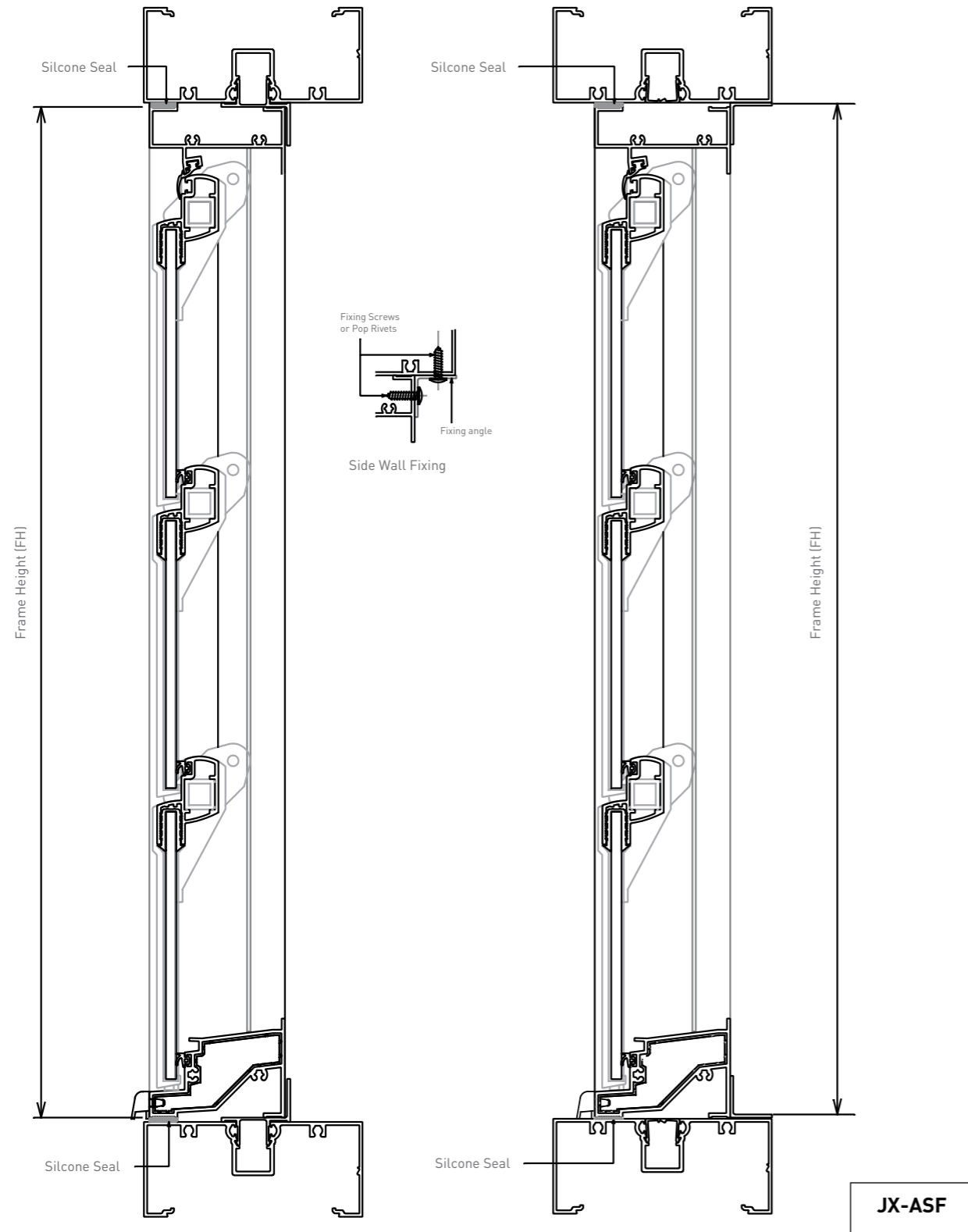

This is an example only.
Consult with your contractor
or installer for specific project
requirements

This is an example only.
Consult with your contractor
or installer for specific project
requirements



Sub-Head & Sub-Sill Installation

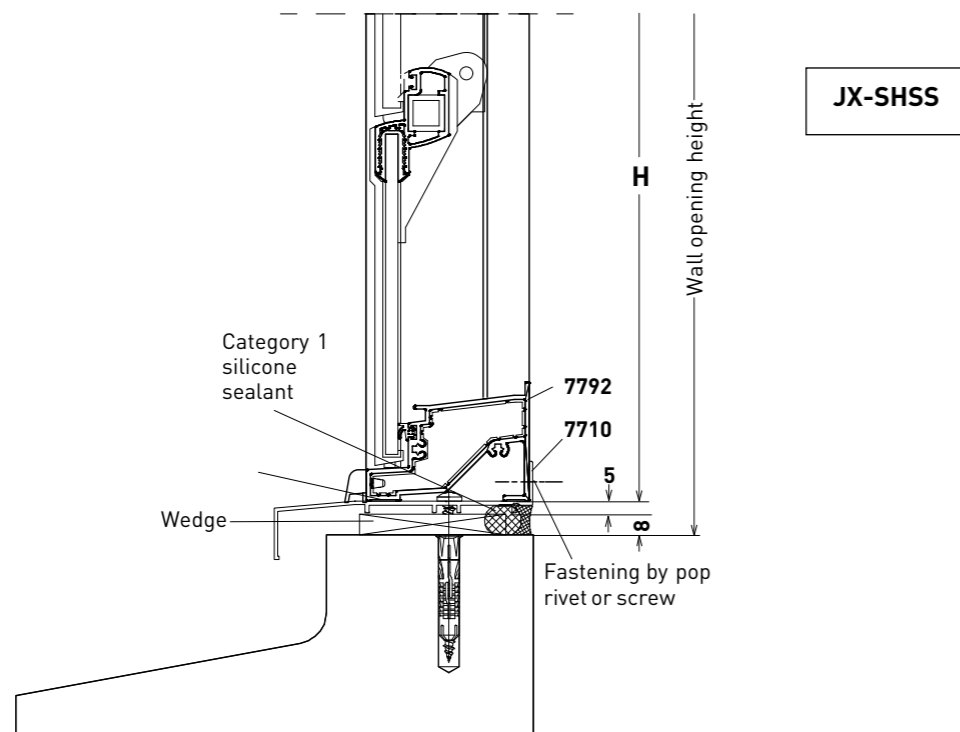
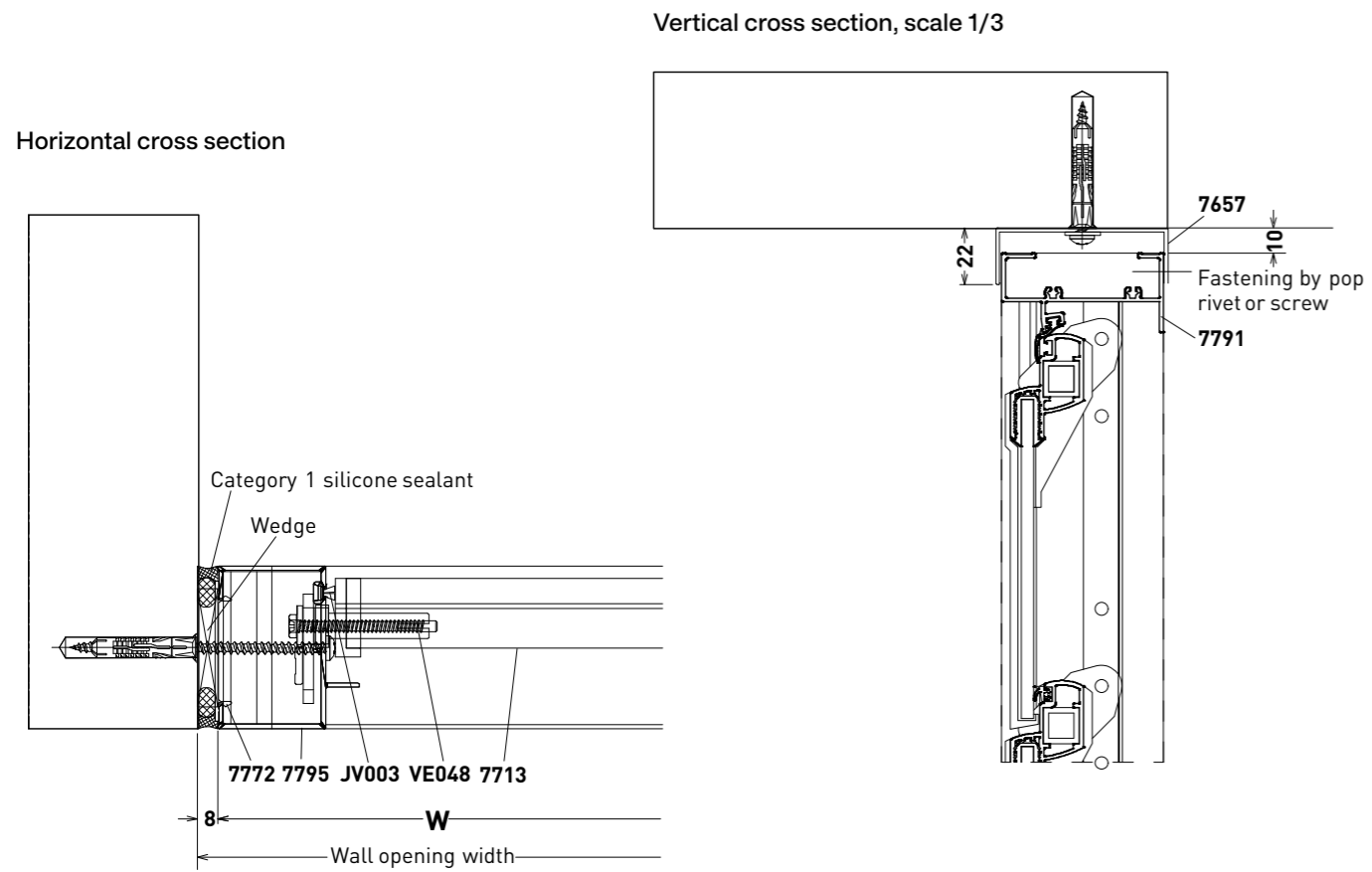

This is an example only.
Consult with your contractor
or installer for specific project
requirements



GUARANTEE

Safetyline Jalousie is a member of the Australian Glass and Window Association and as such conforms to an Industry Code of Conduct designed to protect consumers.

Safetyline Jalousie is inspected by independent third party NATA accredited auditors to validate that the window products examined have been manufactured to the relevant Australian Standards and the legislative requirements of the National Construction Code of Australia.

6 Year Guarantee

Guarantee additional to legal rights.

This Guarantee is provided in addition to any warranty or guarantee imposed by law and in particular the guarantees implied by the Competition and Consumer Act 2010 (Cth). In no way does this Guarantee seek to exclude or limit any right or remedy you have in law. However to the extent that is permitted by law any other warranties or guarantees are excluded. For the purpose of this warranty "the product" means a window product ordinarily manufactured and sold by the manufacturer.

Subject to the conditions and limitations below, Safetyline Jalousie guarantees that its products are of acceptable quality and free of any defect caused by the manufacturer.

Limitations

This warranty does not apply to:

- a) Moving parts – a three year warranty will apply on moving parts which wear out as part of normal use;
- b) Electrical Components – a conditional 3 year warranty for the TJX3701 Internal Drive and the SLJ01 EXT Drive;
- c) Parts supplied by other manufacturers as separate components and where such components are warranted or guaranteed will apply by its manufacturer or supplier those guarantees or warranties whether express or implied are assigned to whom the goods are supplied;
- d) Cosmetic damage;
- e) Damage caused by accident, misuse, transport, installation or any external cause;
- f) Failure to install, use and operate the product in a way that is not in accordance with the manufacturer's instructions, good building practice, relevant building standards or a use for which the product has not been designed or recommended by the manufacturer.
- g) Service work that is carried out by other than the Safetyline Jalousie or authorised Safetyline Jalousie agents.

Warranty Claims

Should you wish to make a claim under this guarantee you are required to first notify the manufacturer. Other than as provided by law, the manufacturer will repair or replace the product to the extent that it is functionally equivalent to the product supplied but excludes any installation costs. Where a product has been repaired or replaced, this warranty shall apply to the repaired or replaced product for the balance of the period provided by this guarantee.



MAINTENANCE

Safetyline Jalousie products are manufactured from the most suitable materials and finishes available to the specification provided and when properly maintained will give many years of quality service. Failure to maintain may void the warranty.

Builders / Home Owners Please Note:

When installing windows there are some precautions you should take to ensure that the products will retain their ex-factory condition until installation is complete and the job handed over.

Windows should be stored in a clean, dry area away from cement, lime, paint, acid etc. and must be protected from building materials and loose debris such as wet plaster, mortar, paint and welding splatter and alike.

- Store in a dry location, under cover where possible, to protect against damage
- Carry windows in the vertical position
- Do not rack frames out of square
- Prevent exposure to moisture

Aluminium

External window frames should be washed with clean water. If the product is exposed to salt air or industrial pollutants it should be washed at least every three (3) months. In rural areas where normally there is very little contaminated moisture you may not need to clean your aluminium fittings more than every six (6) months.

Aluminium requires only minimal maintenance but, like your motor car, the finish may deteriorate if dirt collects on the surface and is allowed to remain unwashed over a period of time. This is because dirt absorbs moisture present in the atmosphere. To clean aluminium use the mildest treatment you can to produce satisfactory results. Start with warm water and soap or detergent or for anodized material try solvent cleaners (e.g. kerosene, turpentine, white spirit) or nonetching chemical cleaners or a wax based polish cleaner. Keep water free from dirt and grit and ensure that the weep slots in the window are clear to allow maximum drainage.

Glass

To clean, simply wipe over the surface with a few drops of methylated spirits on a damp cloth and then polish the surface dry with a lint free cloth. Proprietary glass cleaners are not recommended as some can cause damage to low-E coating and the interlayer in laminated glass. Ensure that all cleaning cloths are free of any abrasive substances. Avoid causing extreme temperature changes as this may lead to thermal fracture of the glass (do not direct hot or cold water onto glass).

Name Plates and Identification Plates

Please leave name plates, part numbers and rating labels on products for future reference. A permanent performance label is a requirement of the BCA in all states and territories of Australia.

SAFETYLINE JALOUSIE

Phone 1300 86 3350

Email sales@safetylinejalousie.com.au

SAFETYLINEJALOUSIE.COM.AU