

Discover an effortless flooring solution with DecoFloor, the revolutionary new timber-look aluminium floorboards by DECO Australia. DecoFloor offers the beauty of natural timber flooring minus the hassle and ongoing maintenance. Made from durable aluminium, it is a long-lasting, non-combustible alternative to timber and laminate floors, and the ideal flooring solution for residential and commercial applications.

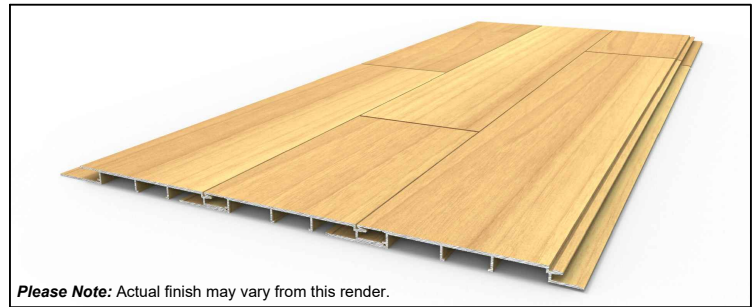
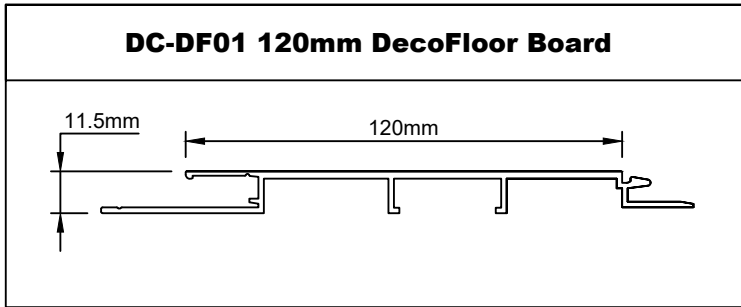

DecoFloor

All DecoFloor profiles and accessories are supplied in 5.4m lengths. As part of the manufacturing process, the first 10mm of both ends of the extrusion are taped and not imaged, therefore each board will need to be trimmed by 15mm on each end to provide a clean finish. After the removal of each end, this gives a usable of 5.37m

Performance

As part of DECO's commitment to providing compliant building products, the DecoFloor system has been designed to meet Australia's stringent building standards. DecoFloor has been tested to and passed the following standards:

DecoFloor - Tested Performance Data		
Description	Standard	Testing Body
Methods for fire tests on building materials, components and structures - Combustibility test for materials	AS1530.1	CSIRO
Methods for fire tests on building materials, components and structures - Simultaneous determination of ignitability, flame propagation, heat release and smoke release	AS/NZS1530.3	CSIRO
Method of test for heat and smoke release rates for materials and products using an oxygen consumption calorimeter	AS3837	CSIRO
Methods for slip resistance test on pedestrian surface materials - Wet Pendulum Slip Resistance Test - Class: P2	AS4586-2013	SLIP CHECK
DecoFloor - Assessed Performance Data		
Clause	Assessment Outcome	
NCC 2019 - Volume 1 - Clause C1.9 Non-Combustible building elements	Compliant	

Please Note: All testing has been undertaken using the detail provided in this installation guide and in order to claim the performances set out here within, the detail in this guide must be followed.

Warranty for DECO Products & Finishes

DECO Australia warrants that DECO finishes have been applied in accordance with the Australian Standard for Architectural Powder Coating AS 3715. The warranty is for 12 years and is subject to the provisions set out in AS 3715, including maintenance and cleaning, as set out in Appendix C of the standard.



Please note that if a formal warranty certificate is required, this must be applied for at the time of order. This is because the standard requires DECO Australia to process specimens for testing and reference at the same time as the job is processed. A warranty application form can be obtained by contacting DECO Australia by phone or email.

Contact your DECO Representative on (02) 9603 1888 for more information.

Intellectual Property

This document and the information contained within it are copyright and confidential to DECO Australia®. Disclosure, use and copying in any form, except as authorised by DECO Australia® in writing are prohibited. Patents and Design Registrations Pending.

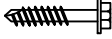
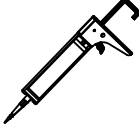
DecoFloor Suggested Installation Tools & Products

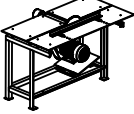
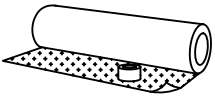
	<p>CLIPFIX CONCRETE SCREWS 5 x 32MM (galvanised or stainless steel)</p> <p>Supplied by Installer or DECO</p>		<p>SEALANT/ADHESIVE DECO recommends the use of high-quality sealants and adhesives.</p> <p>Supplied by Installer</p>
	<p>IMPACT DRIVER A high-quality Impact Driver with an appropriate driver bit is recommended for fixing all extrusions to the building structure.</p>		<p>MITRE SAW A high-quality Mitre Saw equipped with an aluminium cutting blade is recommended for cutting the boards to length and trimming the board ends.</p>
	<p>TABLE SAW A high-quality Table Saw is recommended for ripping the final board to the correct dimension for finishing of the installation. (May or may not be required)</p>		<p>UNDERLAYMENT High quality underlayment is strongly recommended for installation. This provides stability, noise reduction and supports the locking system.</p> <p>Supplied by Installer</p>

DecoFloor Accessories

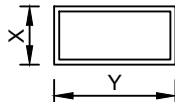
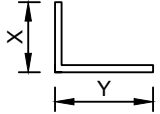
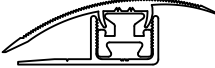
	<p>MF-DF02 - STARTER FLAT BAR The Starter Flat Bar 20mm x 1.6mm is the base profile that helps to level the first board to begin the installation. The Starter Flat Bar is required to be attached to the first row of DecoFloor boards.</p>		<p>RECTANGULAR HOLLOW DESIGNS For use as Skirting, RHS can be supplied in various sizes and colour matched to the finish you require.</p>
	<p>ANGLE For use as Skirting and Transitioning. The Angle can be supplied in various sizes and colour matched to the finish you require.</p>		<p>CARPET CONNECTOR (Available on Request) For use in transitioning between two areas: Flooring and Carpet. It contains 3 Parts, including Base, Joiner, and Ramp. DECO can colour match the ramp to the desired finish.</p>

Skirting and Transitioning

DECO can supply aluminium Skirting and Transition Trims and they can be colour matched to the finish you require. However, a wide range of Skirting and Transitioning options are available in the flooring market, and many different options can be used with DecoFloor depending on the nature of your project. For more information please contact your DECO representative (02) 9603 1888.

Skirting

DECO offers two options for Skirting with the DecoFloor product: Rectangular Hollow Section and Angle Strip. However, as there are a wide range of Skirting options available in the flooring market, these are only two of many skirting options compatible with DecoFloor.

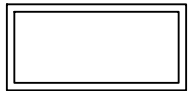
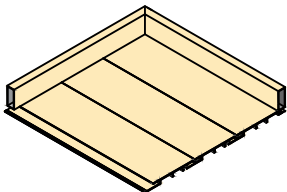
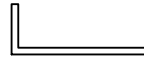
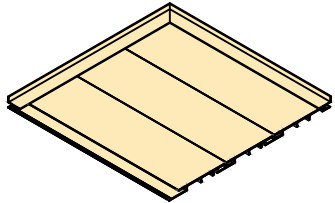
 <p>RHS</p>		 <p>Angle</p>	
------------------------------------------------------------------------------------------------------	-------------------------------------------------------------------------------------	----------------------------------------------------------------------------------------------------------	---------------------------------------------------------------------------------------

Transitioning

DECO offers two options for transitioning to other surfaces with the DecoFloor product, including an Angle Strip for general transitions and a Carpet Connector for carpet transitions. However, as there are a wide range of transitioning options available in the flooring market, these are only two of many transitioning options compatible with DecoFloor.

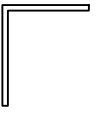
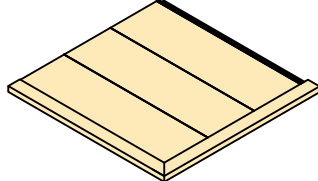
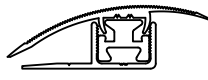
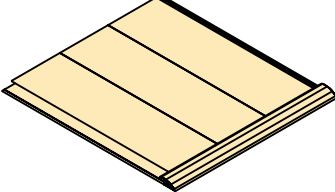
 <p>Angle</p>		 <p>Carpet Connector</p>	
---------------------------------------------------------------------------------------------------------	-------------------------------------------------------------------------------------	---------------------------------------------------------------------------------------------------------------------	---------------------------------------------------------------------------------------

Preparation

Installation Surface

When installing DecoFloor, care should be taken to adequately prepare the installation surface, to ensure it is fit for its intended purpose. Before installing the boards, care should be taken, the surface should be levelled to remove any depressions in the floor. DecoFloor is intended to be installed on a subfloor that is solid, hard, flat, clean, dry and structurally stable, such as concrete base or wood substrates, and preparations including laying high quality underlay should be completed prior to installation.

Fixing Details

When fixing DecoFloor products, it is recommended that they are screw fixed at a minimum of 1200mm centres when applied to a solid floor base, and roughly 20-50mm before the end of each board.

Processing of DecoFloor

WARNING - When processing DecoFloor, care should be taken and appropriate Personal Protective Equipment should be worn at all times. Failure to do so risks potential serious injury, disablement or death. When processing DecoFloor, care should be taken to ensure that the workspace is clean and free from dust, sawdust, metal fines and/or shavings. Processing of the floor boards in areas with excessive dust, sawdust, metal fines and/or shavings risks potential damage to the finished surface.

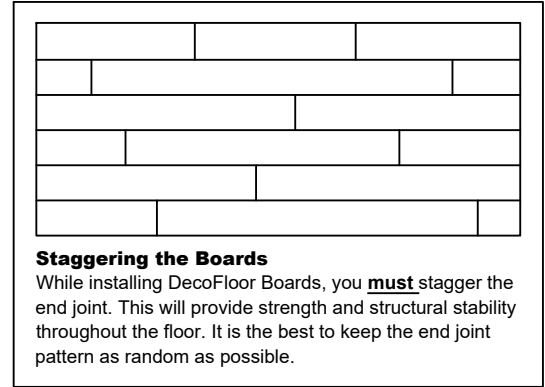

STEP 1 - Install the First Board

Installing the first board requires a starter flat bar (MF-DF02) to level the DecoFloor board.

Use screws to fix the DecoFloor board and the starter flat bar toward the floor base (see in DETAIL A). **Please Note:** Pre-drilling is recommended throughout the installation.

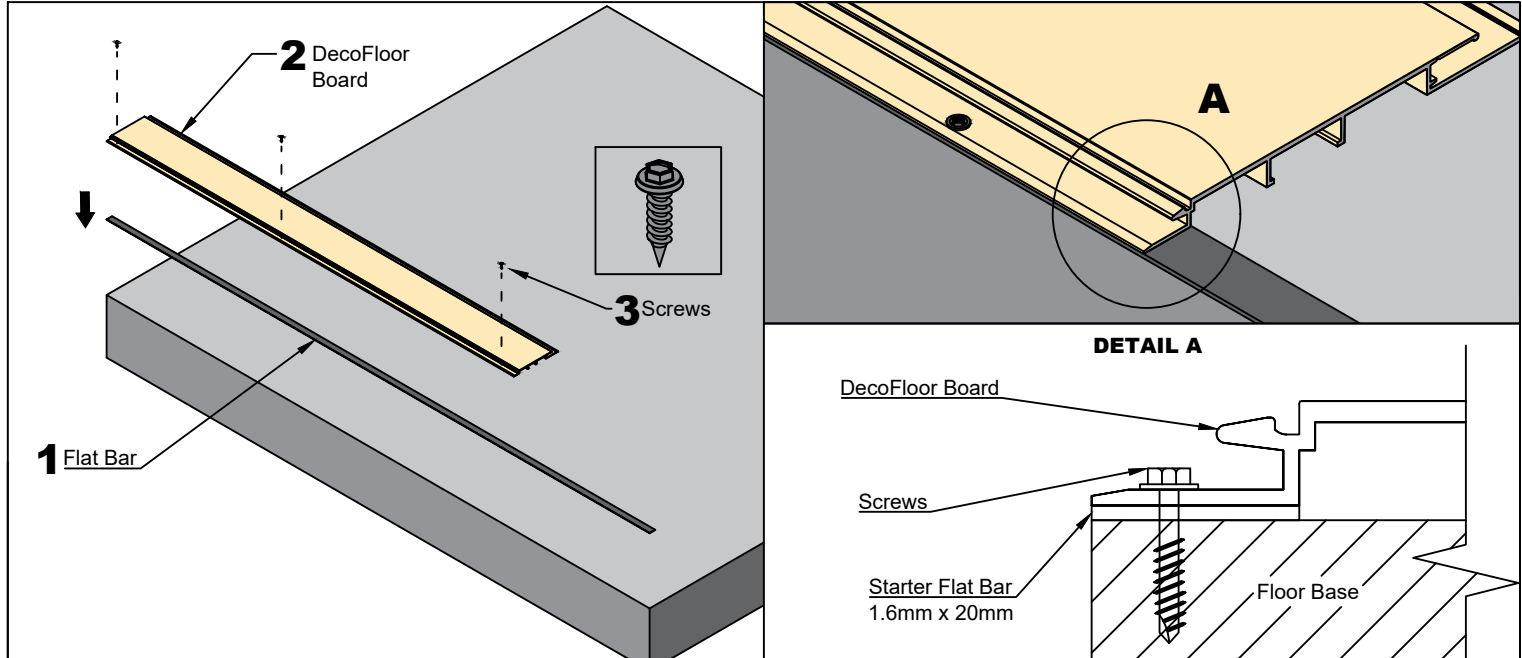

STEP 2 - Fixing the First Board

Fixing the first row of boards requires screws on both sides of the board (see DETAIL B).

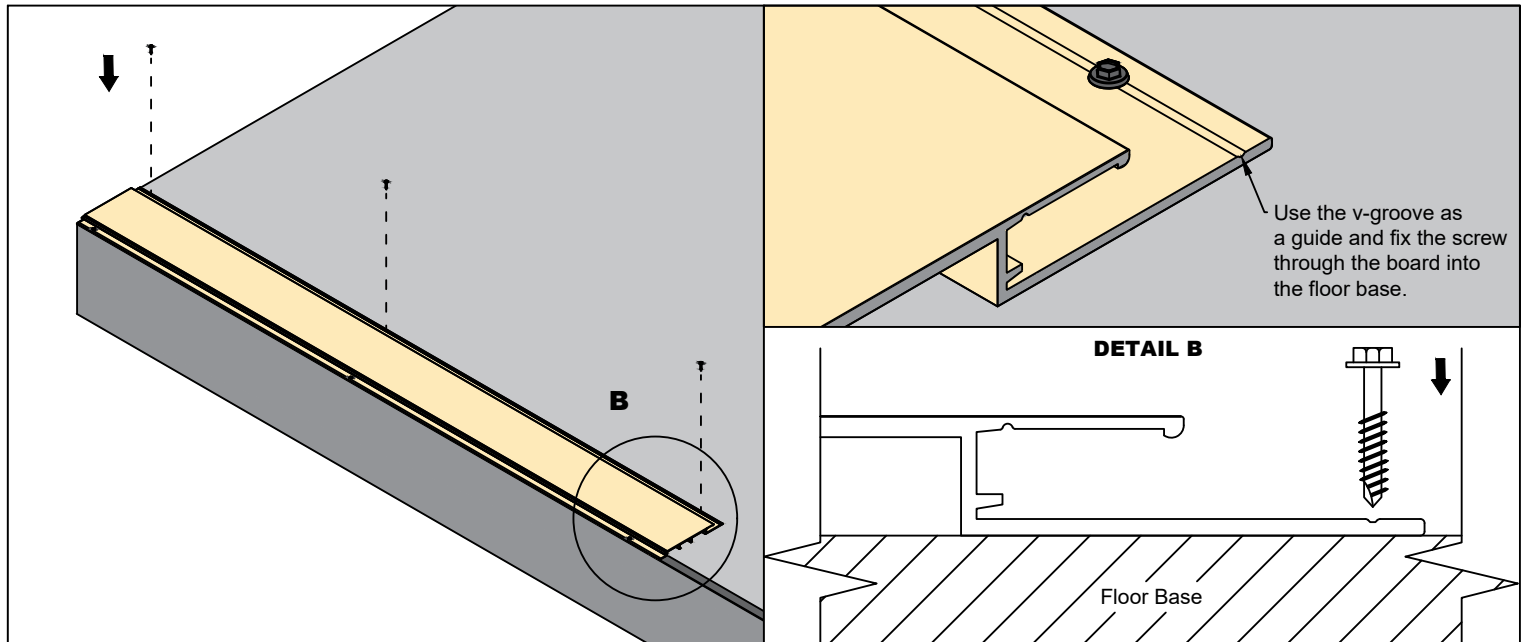

STEP 4 - Installing the Second Row

The second row of DecoFloor boards can be "snapped" together with the first row of DecoFloor boards (see DETAIL D), and the back of the boards can be screw fixed (see DETAIL B at Page 3). **Please Note:** Light tapping with a rubber mallet on a tapping block is recommended to install. Ensure the block is located against the bottom edge of the floor board (see DETAIL C). Tapping block protects the edge of the boards from the mallet.

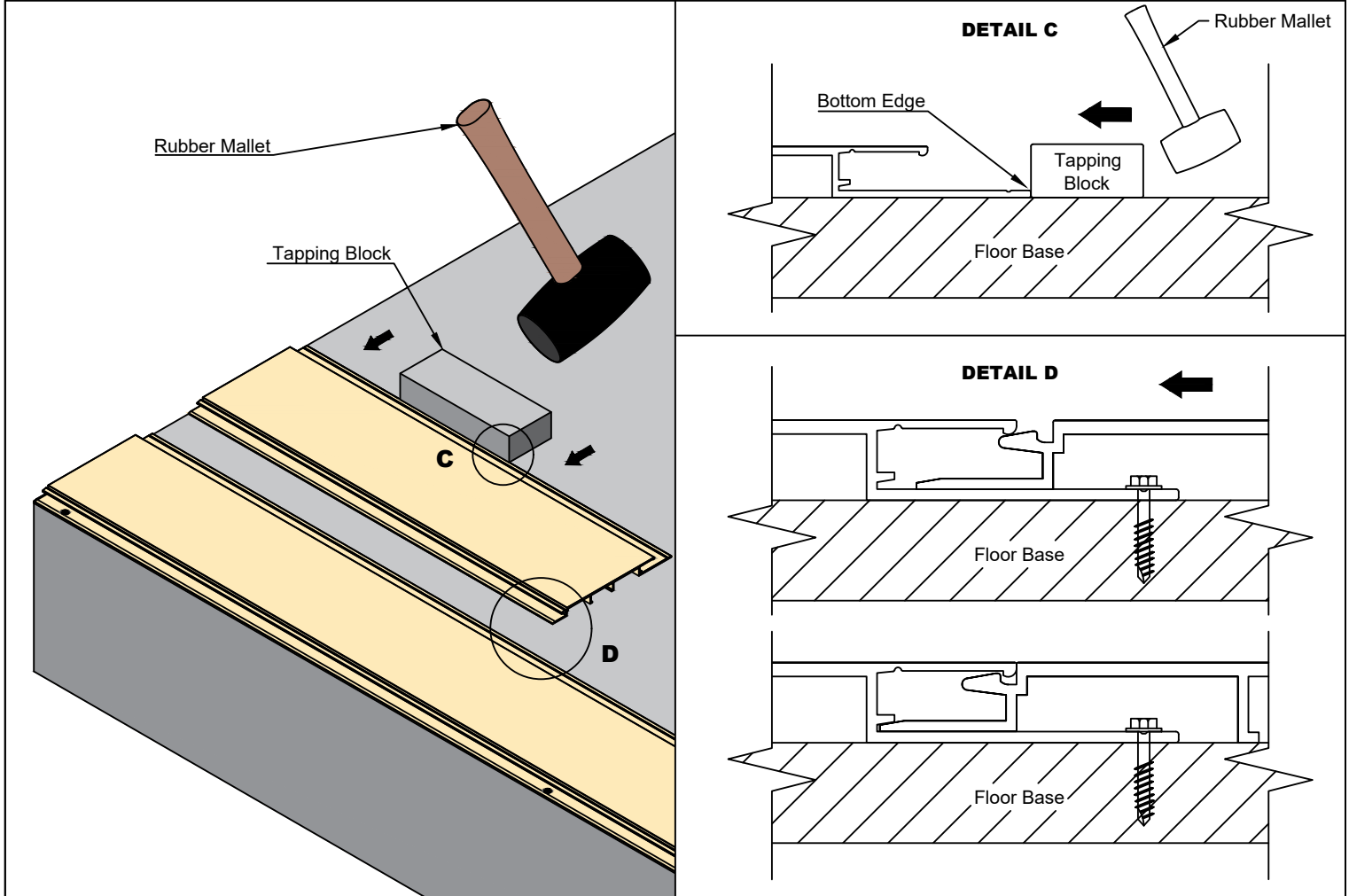

STEP 5 - Installing additional Floor Board and Fix as Required

Repeat step 4 until the desired flooring area is covered by DecoFloor boards. **Please Note:** Ensure you keep a staggered design.

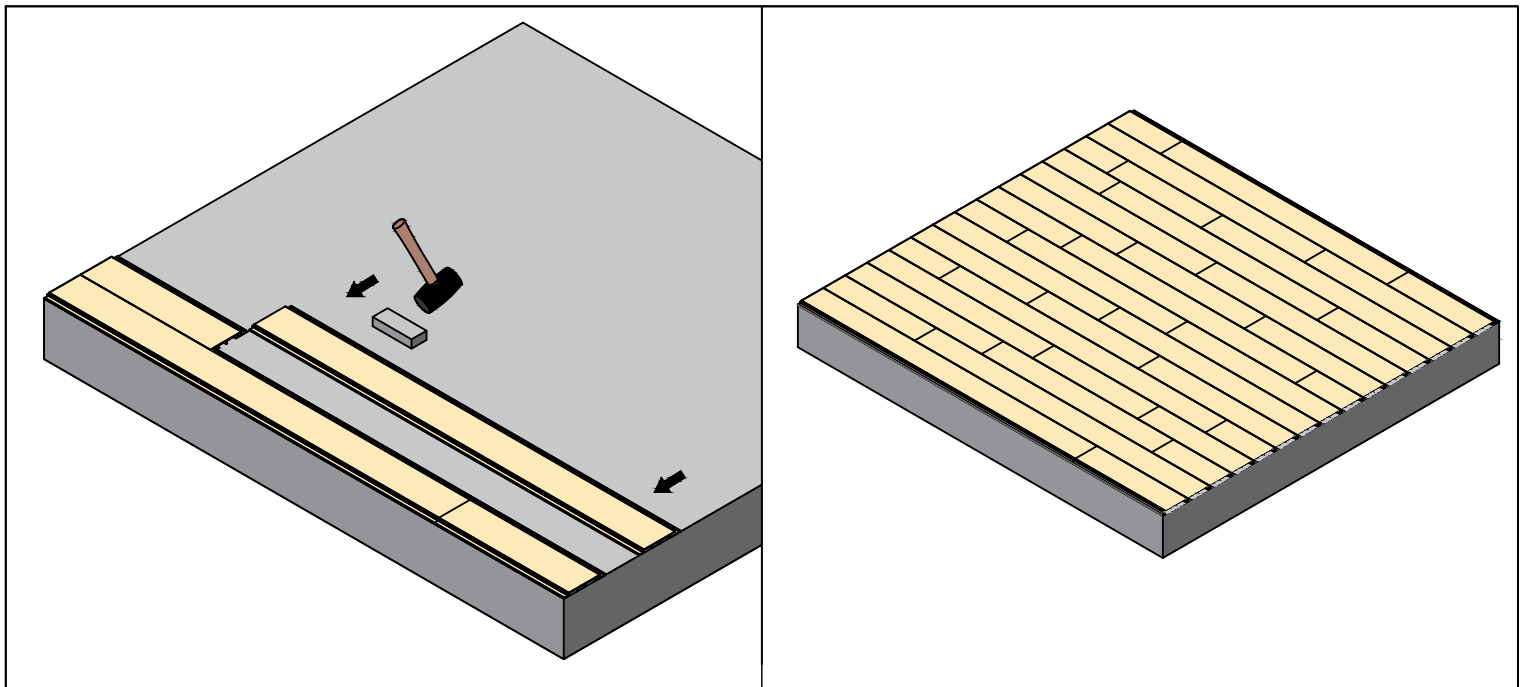

Adhesive Fixing

When applying adhesive fixing, it is recommended high quality adhesives are used across the installation.

Processing of Transition Trims

WARNING - When processing aluminium Transition Trims, care should be taken and appropriate Personal Protective Equipment should be worn at all times. Failure to do so risks potential serious injury, disablement or death. It is important to ensure that the workspace is clean and free from dust, sawdust, metal fines and/or shavings. Processing aluminium Transition Trims in areas with excessive dust, sawdust, metal fines and/or shavings risks potential damage to the finished surface.

Transition Trims Installation Recommendation

The following guide is a recommendation for installing the Transition Trims for DecoFloor board. All the Transition Trims require constant pressure in a specific direction for 24 hours to settle the adhesive if required.

Carpet Connector - Transition from Flooring to Carpet

A Carpet Connector can be used to connect your DecoFloor to an adjacent carpeted area and hide any transition steps.

STEP 1 - First, install the Carpet Connector Base to desired location by applying adhesive underneath. Ensure adhesive is set before moving on to STEP 2.

Please Note: Make sure the Carpet Connector Base is tucked under the edge of the carpet.

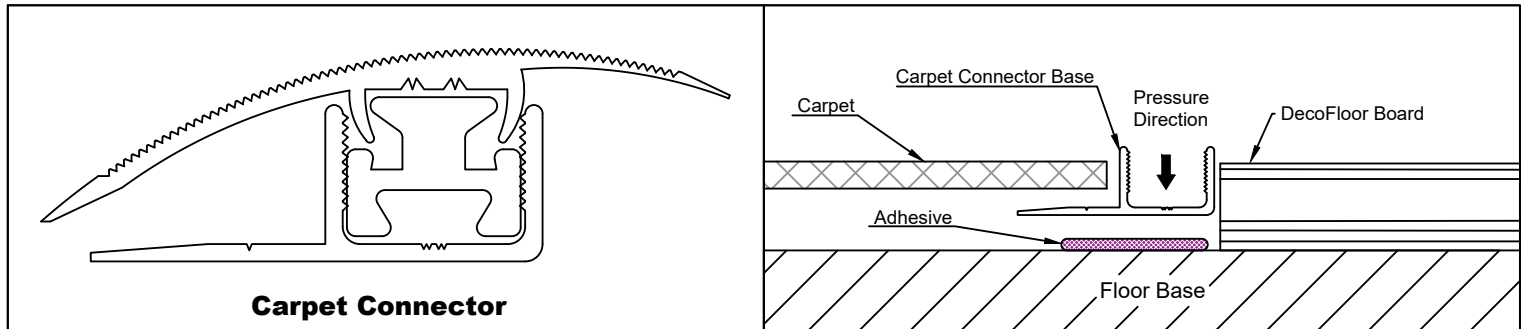

STEP 2 - Slide in the plastic joiner into the ramp.

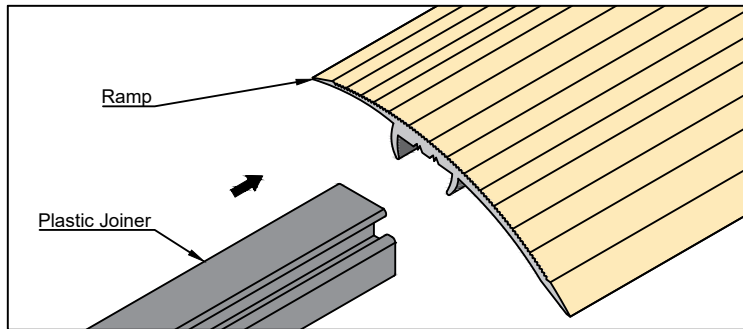

STEP 3 - Finally insert the ramp and joiner into the base.

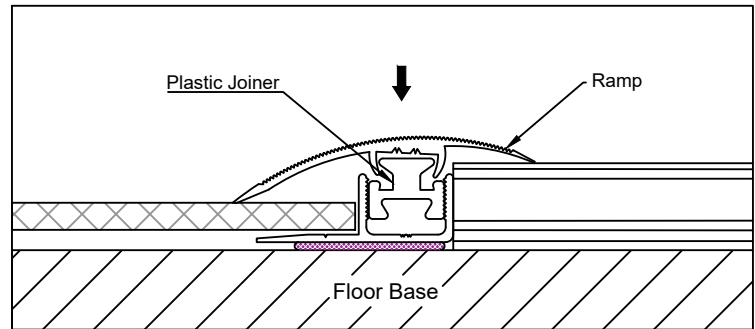

Angle - End Profile Transition

The Angle can be used in general transition from flooring to different areas, as well as covering the corner of exposed end of a step-down.

Apply adhesive to the desired location, then apply the Angle and apply constant pressure until the adhesive is set. A screw can also be applied to the front face for added security if required.

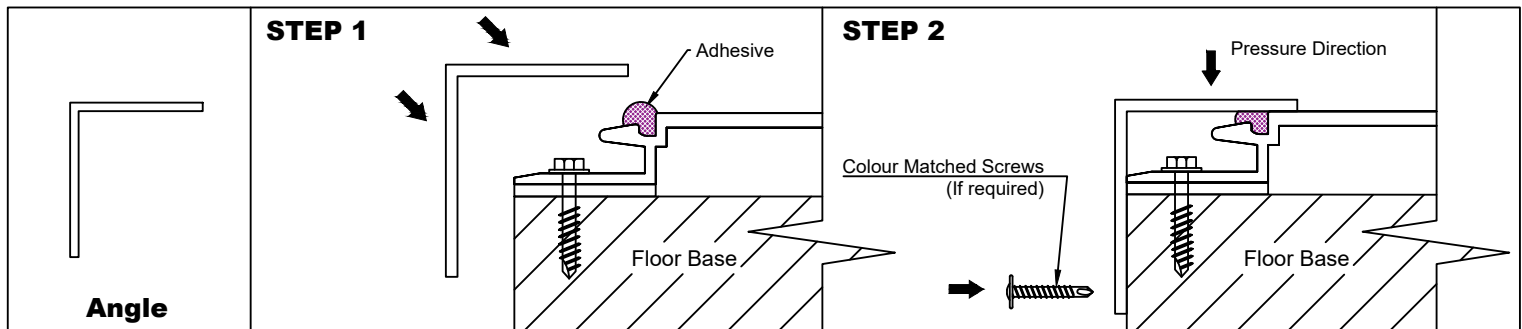

INSTALLATION GUIDE

Skirting Board

Adhesive Fixing

When applying adhesive fixing, it is recommended high quality adhesives are used across the installation.

Processing of Skirting Board

WARNING - When processing aluminium Skirting Boards, care should be taken and appropriate Personal Protective Equipment should be worn at all times. Failure to do so risks potential serious injury, disablement or death. It is important to ensure that the workspace is clean and free from dust, sawdust, metal fines and/or shavings. Processing aluminium Skirting Board in areas with excessive dust, sawdust, metal fines and/or shavings risks potential damage to the finished surface.

Skirting Installation Recommendation

The following guide is a recommendation for installing the suggested Skirting Board for DecoFloor board. Skirting is used to cover up any expansion gaps around the room perimeter. The skirting system requires constant pressure on a specific direction for 24 hours to settle the adhesive if required.

Rectangular Hollow Section - Cover Expansion Gaps around Room Perimeter

RHS can be used to cover expansion gaps that are left around the room perimeter. Apply adhesive to the wall and DecoFloor Board, then apply the RHS with constant pressure toward the wall and downward until adhesive is set. Masking tape can be used to hold the section in place if required.

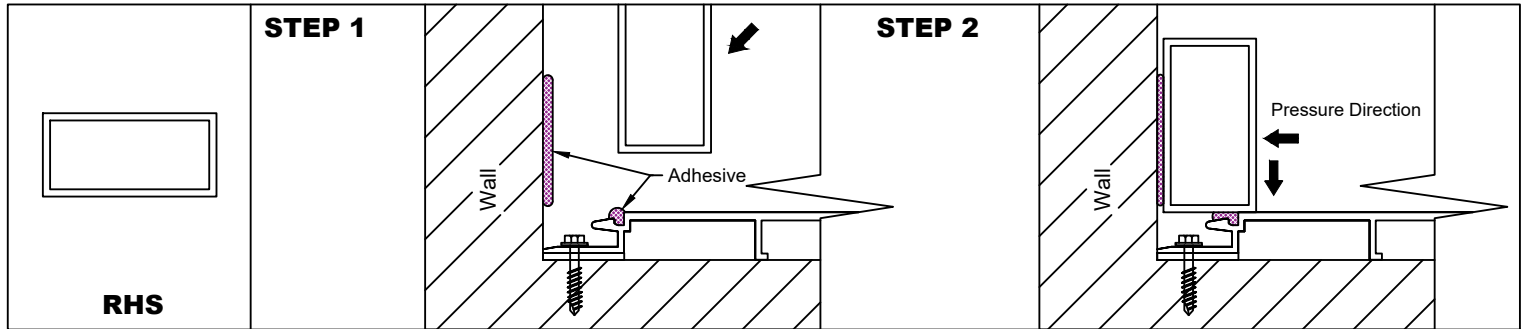

Angle - Cover Expansion Gaps around Room Perimeter

Angles are another way to cover expansion gaps that are left around the room perimeter. Apply adhesive to the wall and DecoFloor Board, then apply the Angle with constant pressure toward the wall and downward until adhesive is set. Masking tape can be used to hold the section in place if required.

