

**DC-DSL3816**  
DecoSlat  
(38mm x 16mm)

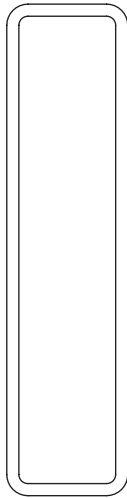

**DC-DSL6516**  
DecoSlat  
(65mm x 16mm)

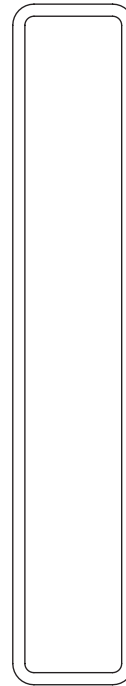

**DC-DSL9016**  
DecoSlat  
(90mm x 16mm)

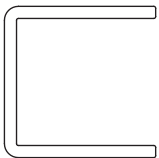

**DC-DCH2020**  
DecoWood Channel  
(20mm x 20mm x 1.6mm)



**DC-DAN2025**  
DecoWood Angle  
(20mm x 25mm x 1.6mm)



**DC-DST**  
Self Tapping 6 Gauge  
15mm Pan Head Screw, Galvanised  
50 Pack

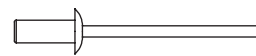

**DC-DPR**  
DecoWood Colour Matched Pop Rivet  
50 Pack

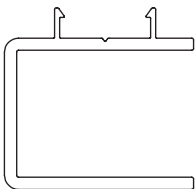

**DC-DCH2PA**  
DecoWood Concealed Channel  
(20mm x 25mm x 1.6mm)

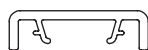

**DC-DCH2PB**  
DecoWood Concealed Channel Cover

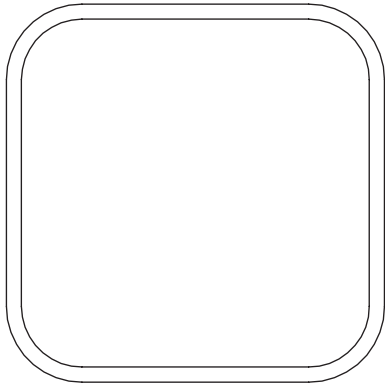

**DC-DP5050**  
DecoWood Post  
(50mm x 50mm x 2.08mm)

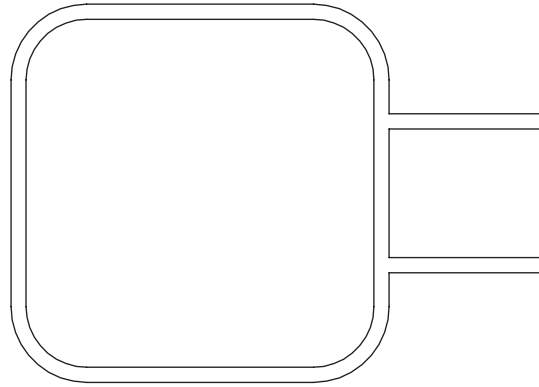

**DC-DG5050**  
DecoWood Gate Frame  
(50mm x 50mm x 2.08mm with Channel)

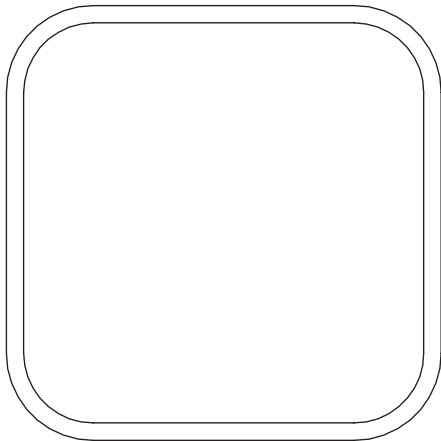

**DC-DP6565**  
DecoWood Post  
(65mm x 65mm x 2.08mm)

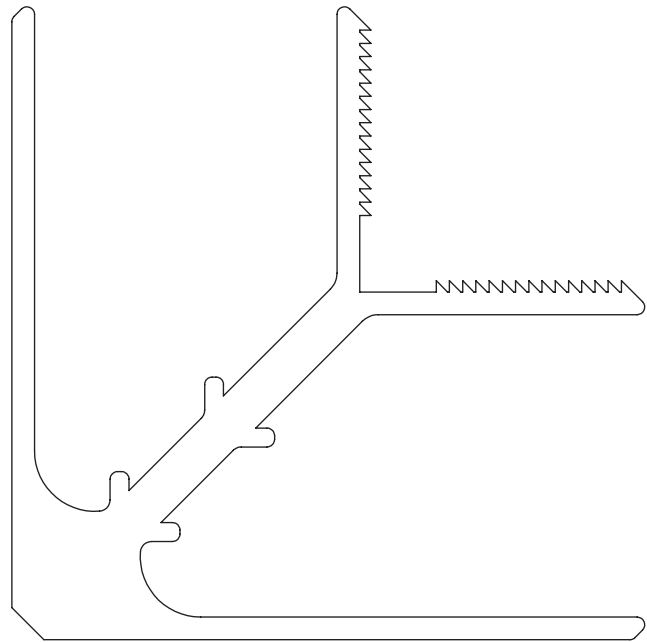

**DC-DGICS**  
DecoWood Gate Internal Corner Stake

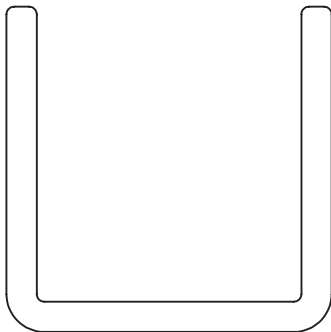

**DC-DPIFS**  
DecoWood Post Internal Foot Stake  
(43mm x 43mm x 4mm)

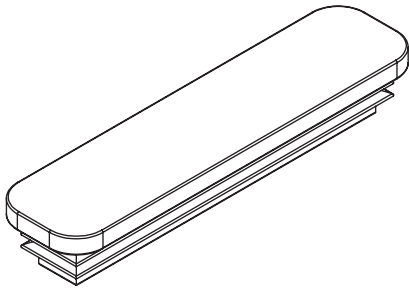

**DC-DSL6516-EC-BP**  
Black Plastic End Cap  
(65mm x 16mm)

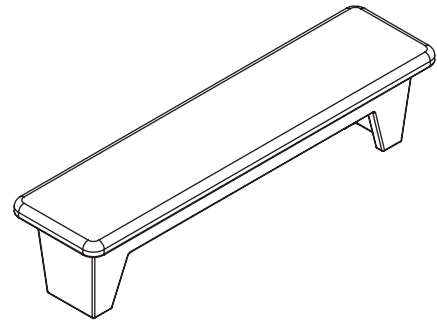

**DC-DSL6516-ECL**  
Metal End Cap – Colour Matched  
(65mm x 16mm)

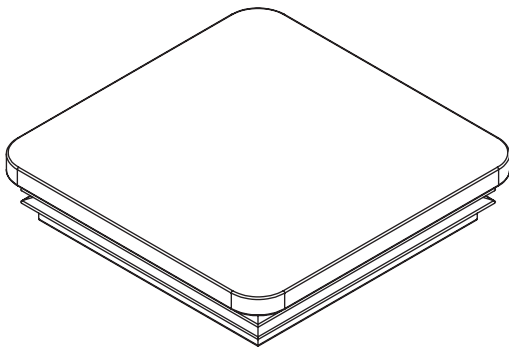

**DC-DP5050-EC-BP**  
Black Plastic End Cap  
(50mm x 50mm)

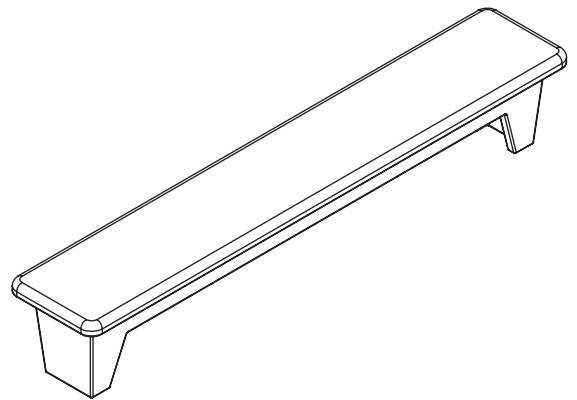

**DC-DSL9016-ECL**  
Metal End Cap – Colour Matched  
(90mm x 16mm)

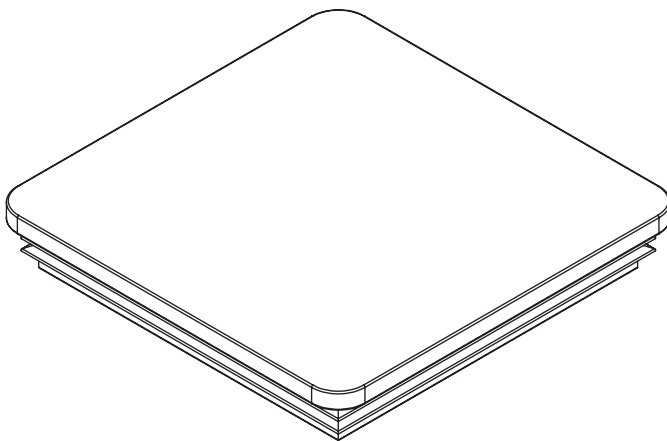

**DC-DP6565-EC-BP**  
Black Plastic End Cap  
(65mm x 65mm)

OVERVIEW:

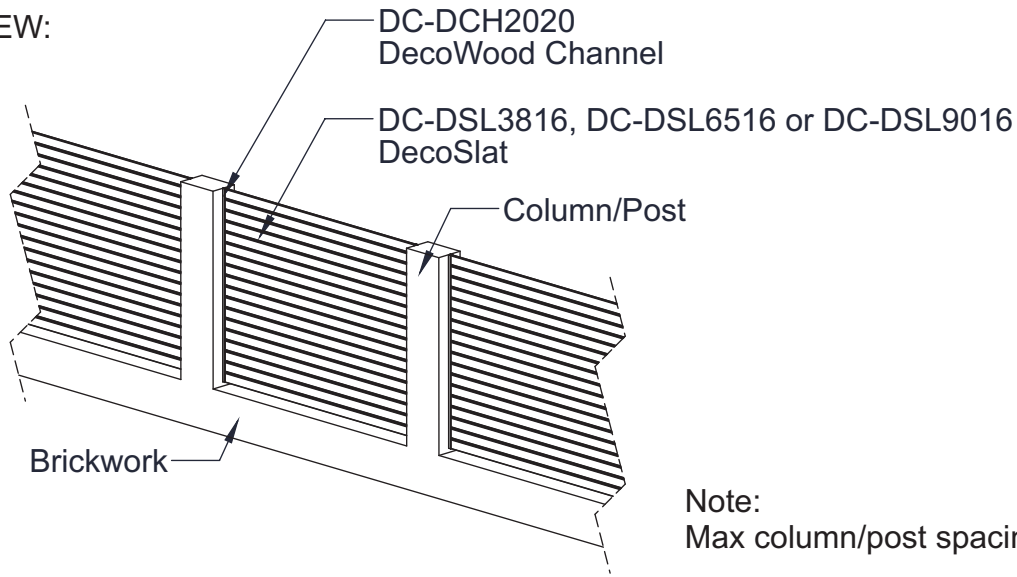

STEP ONE: Attach channel to columns/posts using screws/pop rivets.

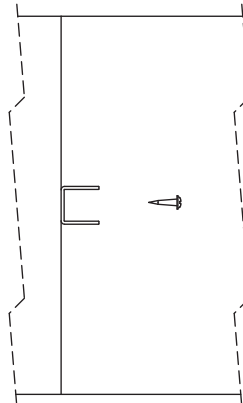
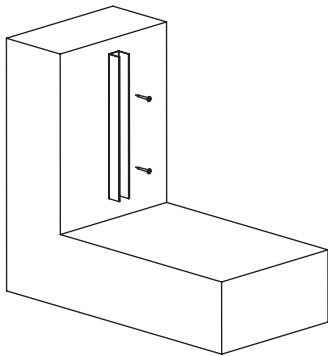

STEP TWO: Slide the DecoWood slats into the channel and fix the DecoWood Slats into position using pop rivets. Set even gaps between the slats using temporary plastic packers.

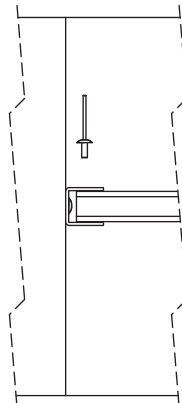
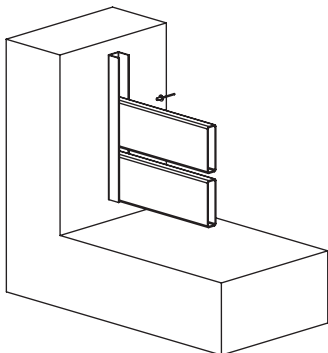

**OVERVIEW:**

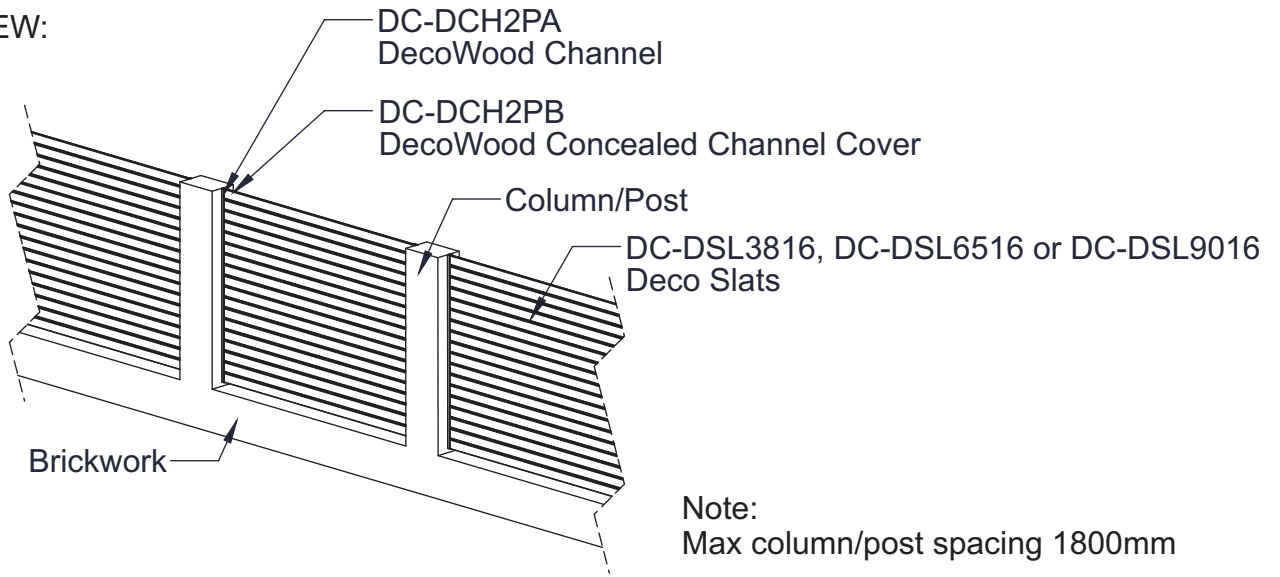

**STEP ONE:** Attach concealed channel to columns/posts using screws.

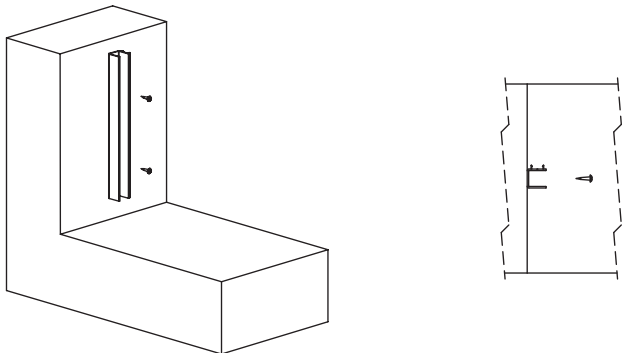

**STEP TWO:** Slide the DecoWood slats into the channel and fix the DecoWood Slats into position using self-tapping screws. Set even gaps between the slats using temporary plastic packers.

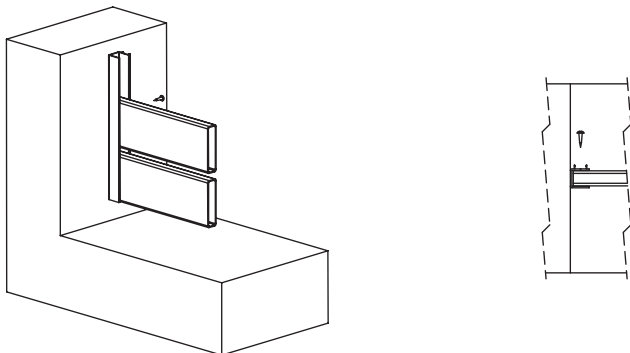

**STEP THREE:** Snap the concealed channel cover onto the concealed channel.

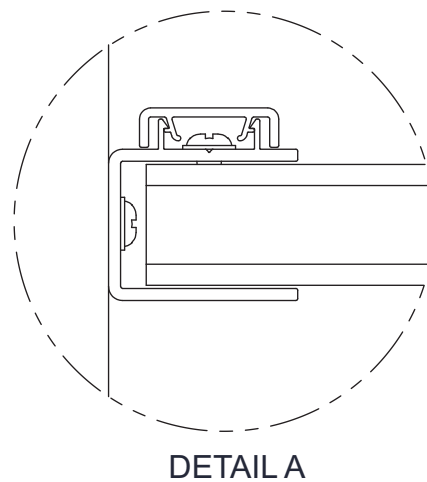
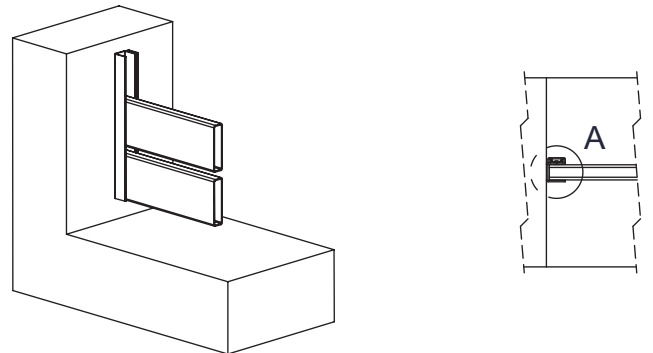

**OVERVIEW:**

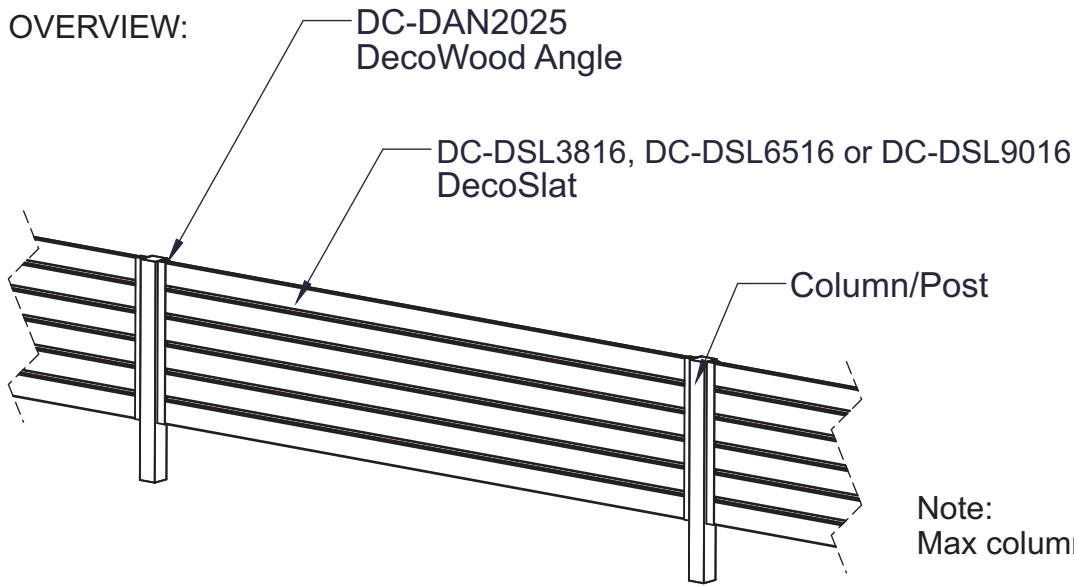

Note:  
Max column/post spacing 1800mm

**STEP ONE:** Assemble a screen of DecoWood Slats - Attach angle to DecoWood Slats using pop rivets or screws. The short side (20mm) of the angle should be on the end/cut face of the DecoWood Slats. Repeat process to both sides. Set even gaps between the slats using

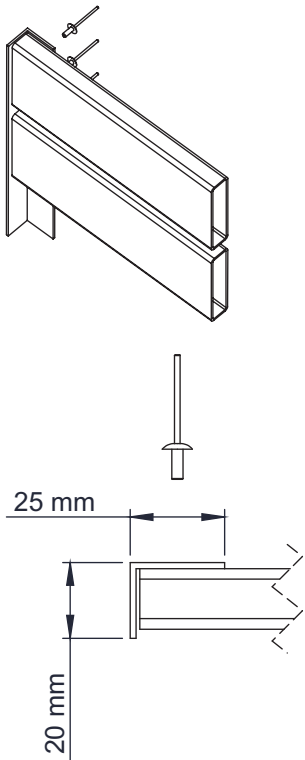

**STEP TWO:** Attach angle to columns/posts using screws/pop rivets.

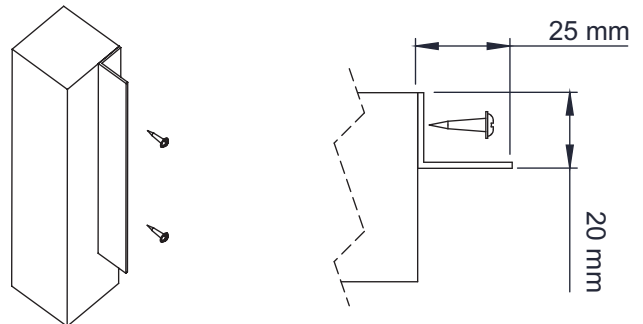

**STEP THREE:** Install the assembled screen of DecoWood Slat between the posts/columns - Attach the screen to the angle using pop rivets or screws - attach to back of slats or between slats.

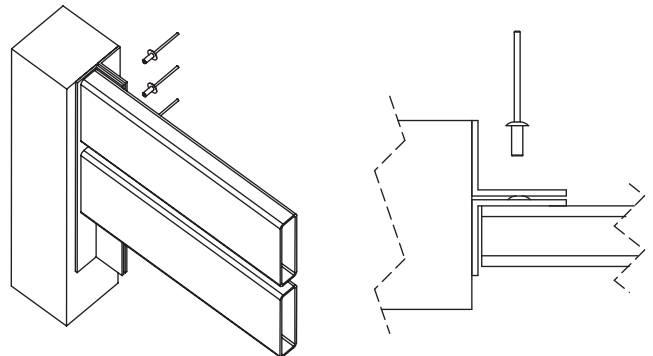

**OVERVIEW:**

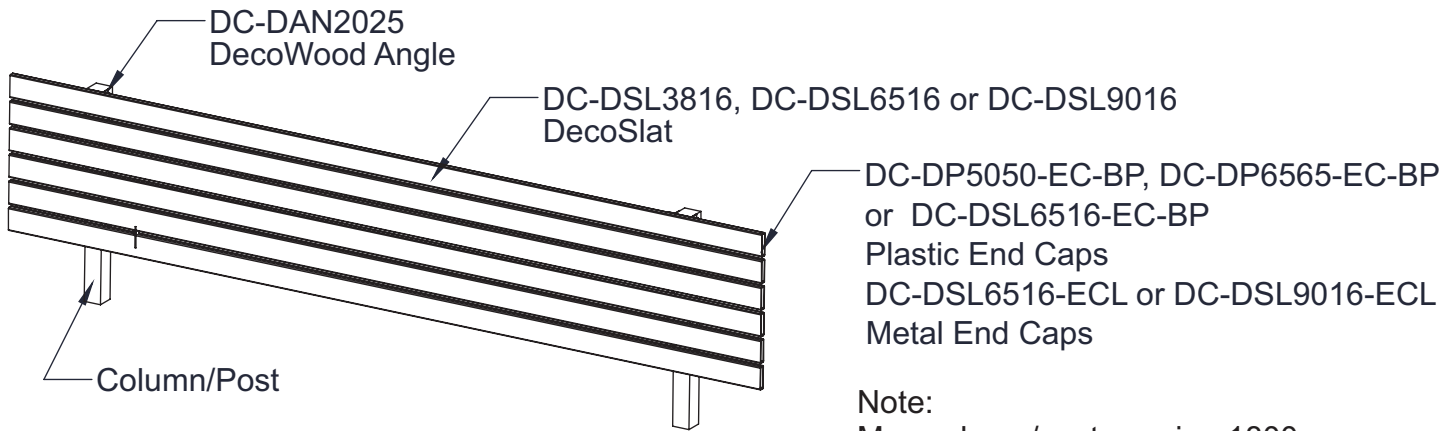

**Note:**  
Max column/post spacing 1800mm.

The column/posts should be secured into position with suitable footing (e.g. concrete) before attaching the DecoWood Slats.

**STEP ONE:** Attach angle to columns/posts using screws. One face of the angle should be flush with the front of the column/post.

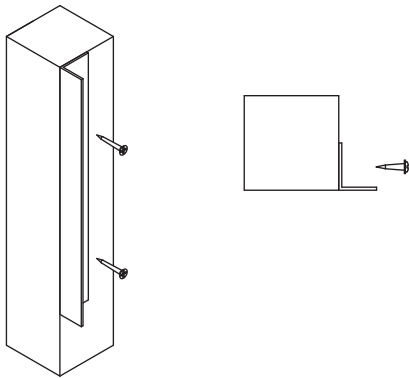

**STEP TWO:** Attach DecoWood slats to the

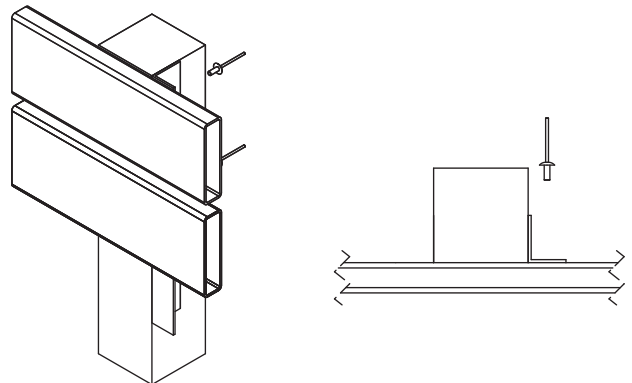

**STEP THREE:** insert end caps into DecoWood Slats using a rubber mallet. (Silicon in place in a marine environment)

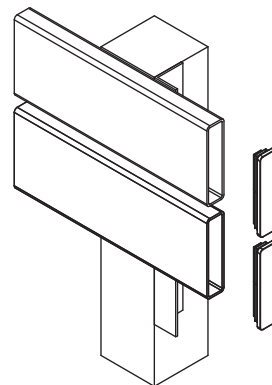



OVERVIEW:

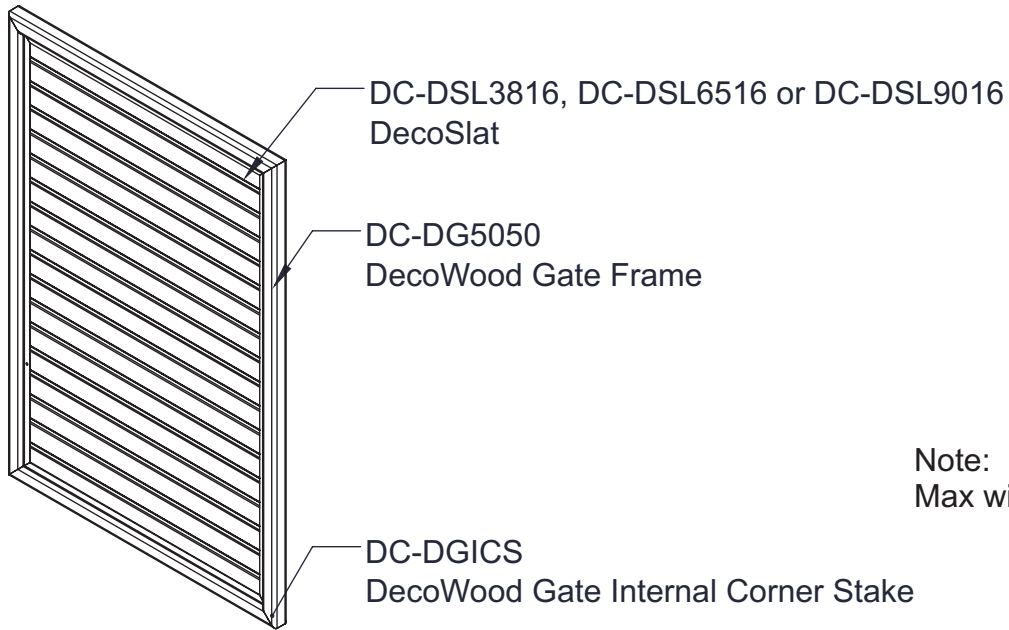

Note:  
Max width 1100mm.

**STEP ONE:** Cut DecoWood Gate Frame to size - cut each end with 45°mitre/angle - the integrated channel should face inwards. The gate must be square i.e. both verticals must be the same length and both horizontals must be the same length.

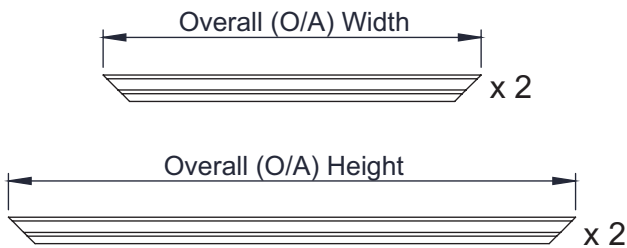

**STEP TWO:** Assemble three sides of the DecoWood Gate Frame using the Corner Stakes. Connect two verticals and one horizontal.

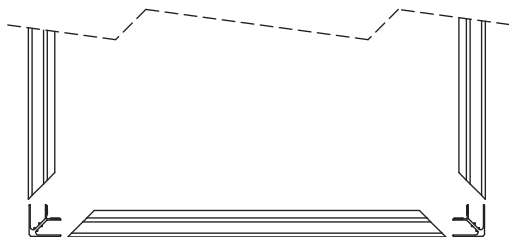

**STEP THREE:** Cut DecoWood Slats to length. Chose quantity to suit the height of the gate, to match a fence and allow for spacing. Slide the DecoWood Slats into the Concealed Channel.

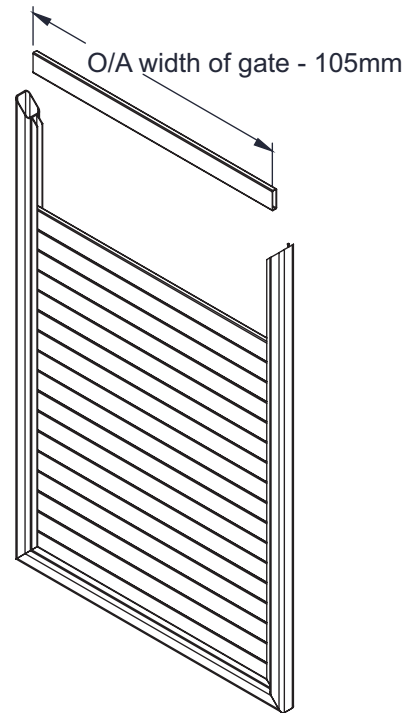

**STEP FOUR:** Assemble final side of the DecoWood Gate Frame using the Corner Stakes. Check and adjust until square. Screw or pop rivet into place - use four on each corner (see Detail View B).

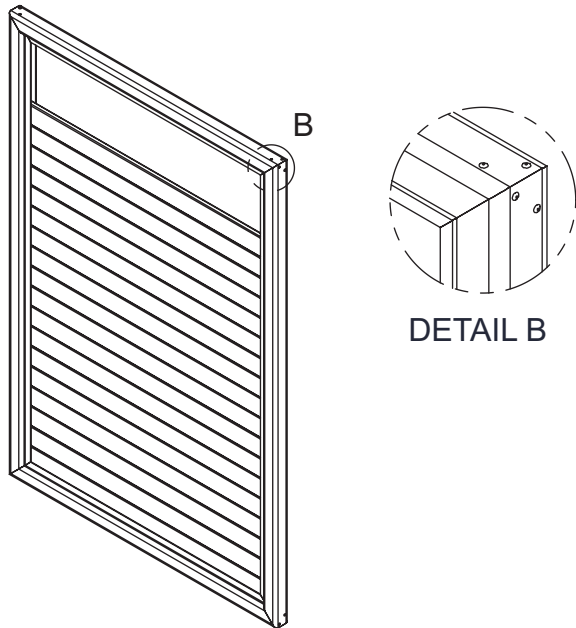

**STEP FIVE:** Space out DecoWood Slats. Set even gaps between the slats using temporary plastic packers. Pop rivet into place - use two pop rivets on both ends of each slat (see Detail View C).

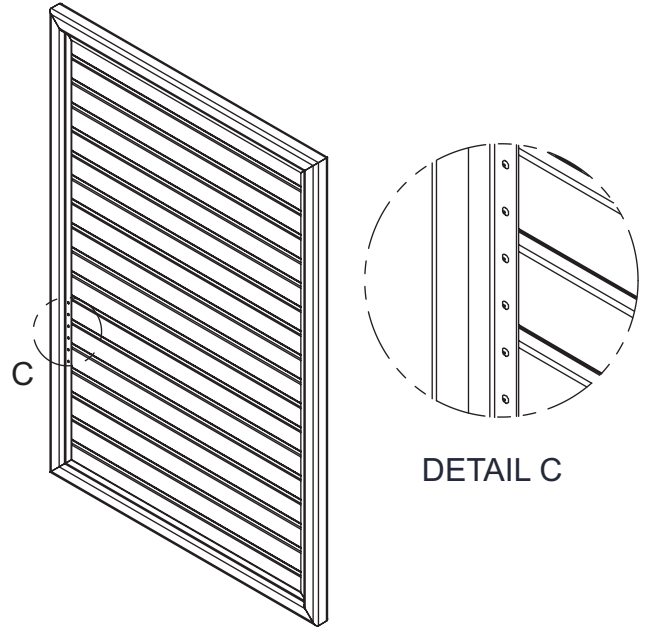

**STEP SIX:** Hang the gate between two DecoWood Posts using standard hinges and locking hardware.

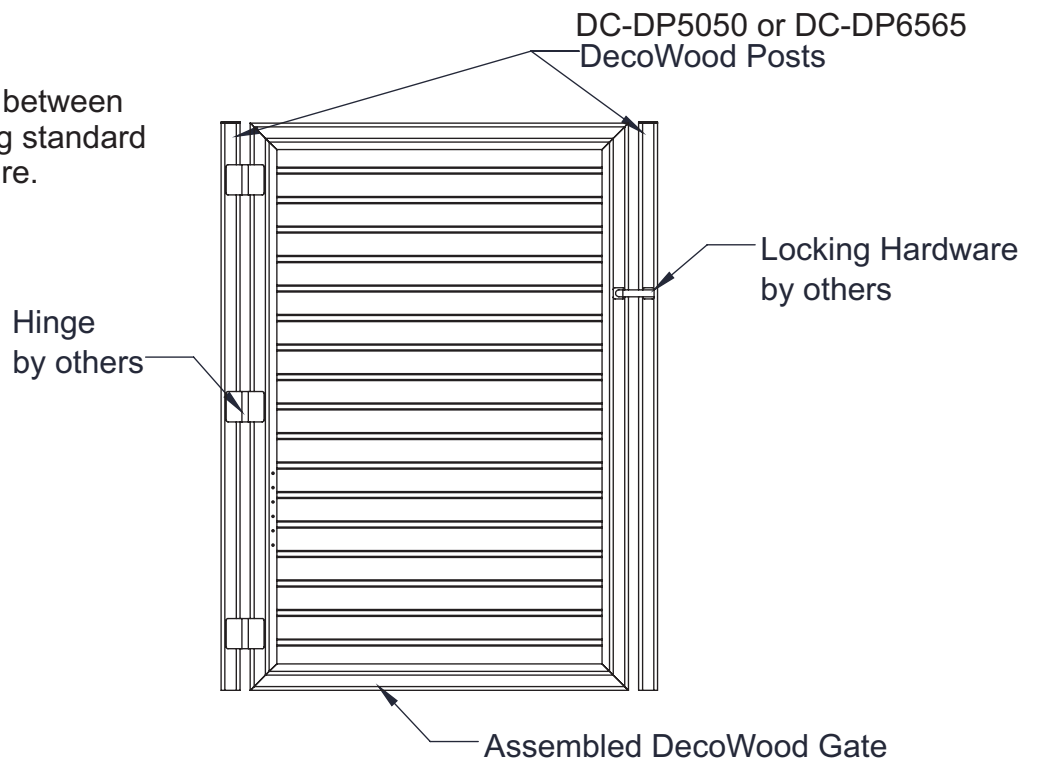

OVERVIEW:

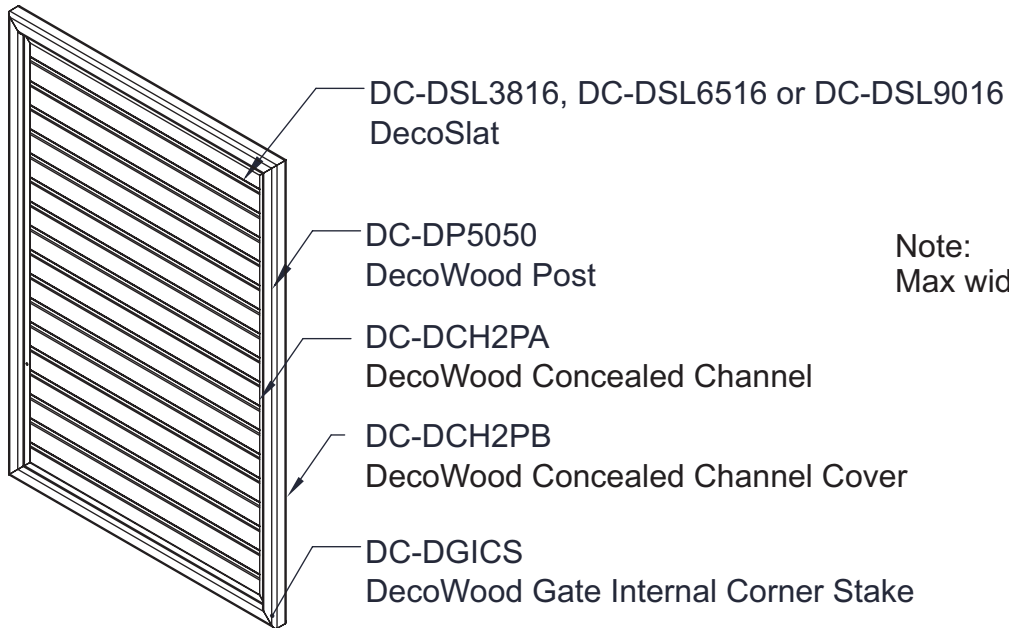

Note:  
Max width 1100mm.

**STEP ONE:** Cut DecoWood Posts to size - cut each end with 45°mitre/angle. These will become the gate frame. The gate must be square i.e. both verticals must be the same length and both horizontals must be the same length.

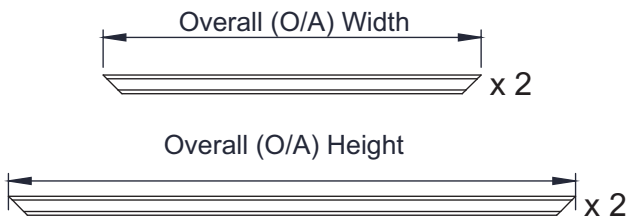

**STEP TWO - A :** Assemble three sides of the DecoWood Post gate frame using the Corner Stakes. Connect two verticals and one horizontal.

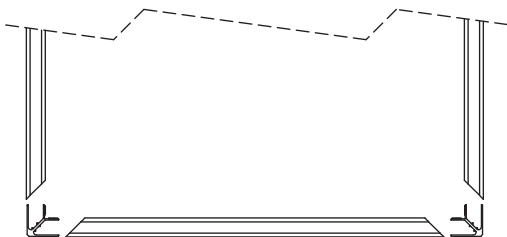

**STEP TWO - B :** Cut Concealed Channel to length. Attach to the gate frame using pop rivets. Attach to verticals only.

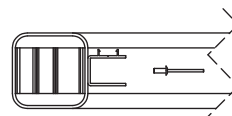
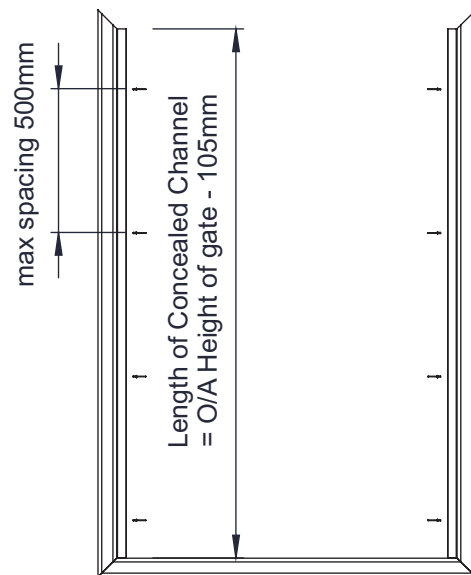

**STEP THREE:** Cut DecoWood Slats to length. Chose quantity to suit the height of the gate, to match a fence and allow for spacing. Slide the DecoWood Slats into the Concealed Channel.

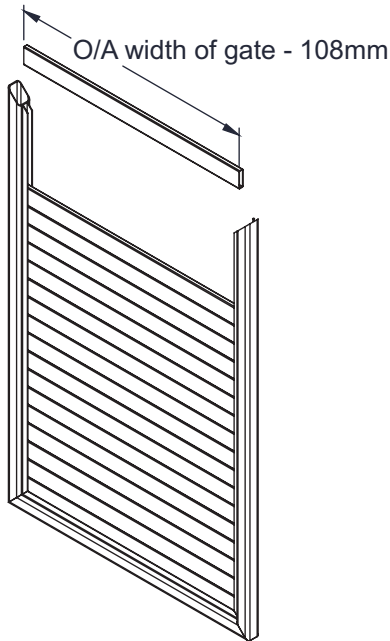

**STEP FOUR:** Assemble final side of the DecoWood Post gate frame using the Corner Stakes. Check and adjust until square. Screw or pop rivet into place - use four on each corner (see Detail View D).

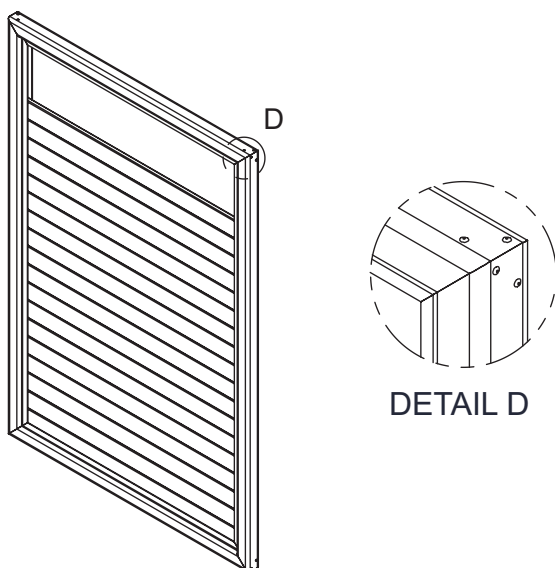

**STEP FIVE - A :** Space out DecoWood Slats. Set even gaps between the slats using temporary plastic packers. Fix the DecoWood Slats into position using self-tapping screws.

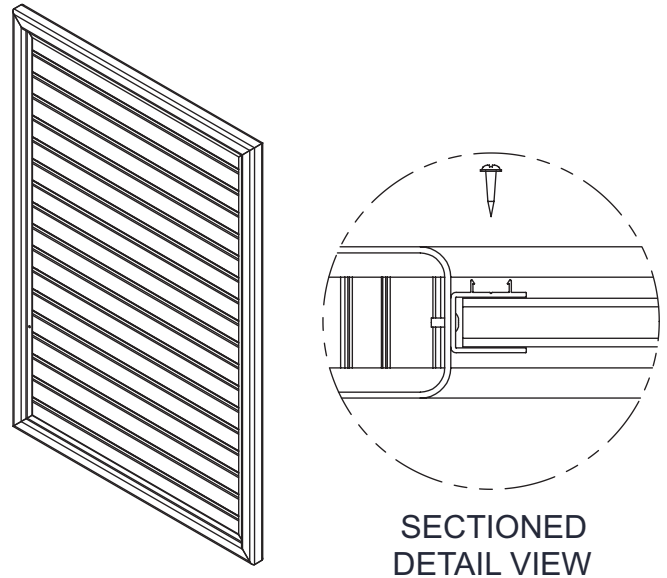

**STEP FIVE - B :** Snap the Concealed Channel Cover onto the Concealed Channel.

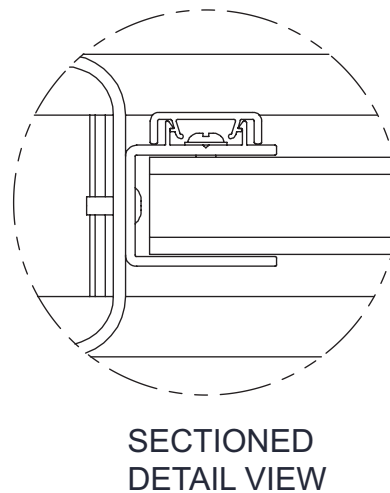

**STEP SIX:** Hang the gate between two DecoWood Posts using standard hinges and locking hardware. See Illustration on page 9.

**TIP ONE:**

Use plastic packers (available from hardware stores) between the DecoSlats when setting out and fixing to maintain neat spaces. 10mm to 20mm is a recommended spacing.

**TIP TWO:**

Aluminium posts, channel and angle can be purchased with DecoWood slats. They are available in colours matched DecoWood finishes for the most popular finishes. Posts and channels are available in all Dulux and Interpon powdercoat colours.

**TIP THREE:**

Colour matched touch-up paint is available in all colours.

**TIP FOUR:**

Colour matched pop rivets are available in all DecoWood finishes.

**TIP FIVE:**

It is the responsibility of the builder/engineer to comply with building codes and structural requirements, however, the suggested maximum height for DecoWood screen using the 50mm x 50mm posts is 1.6 metres. The distance between the vertical supports will vary depending on the location and winds. 1.8 metres is the standard distance between supports, although this can go out to 2.1 metres if necessary.

**TIP SIX:**

Always use a sharp tungsten carbide blade for cutting all DecoSlat products.

**TIP SEVEN:**

All sections come in 6.5m lengths. Try to optimise sizing to match (eg. 4 slats at 1600mm = 6400mm)

**TIP EIGHT:**

Please remember all DecoWood products require a 15mm trim cut on each end, making the usable length 30mm shorter.